

Long Term  
Stability

## Description

Moore Industries' PC-Programmable Temperature Transmitters—the TRY (isolated) and TRX (non-isolated)—combine smart digital technology with advanced analog operation to deliver superior reliability, accuracy and ease of use.

Now with even more flexible capabilities, these 2-wire (loop-powered) analog/digital hybrid transmitters program in a minute or less to accept direct inputs from:

- **23 RTD Types**  
(2-, 3-, and 4-wire; Pt, Cu and Ni; 10 to 1000 ohms)
- **9 Thermocouple Types**  
(J, K, E, T, R, S, B, N, and C)
- **Direct Millivolt Sources**  
(-50 to 1000mV)
- **Resistance & Potentiometer Devices**  
(0 to 4000 ohms)

They convert the input to a highly accurate 4-20mA output that is both linear and scaleable with respect to the input—ready for direct interface with readout instruments, recorders, DCSs, and other computer-based SCADA systems.

**Figure 1.** Compact yet powerful, the 2-wire TRY and TRX transmitters afford full programmability in a rugged, ready-to-install assembly.

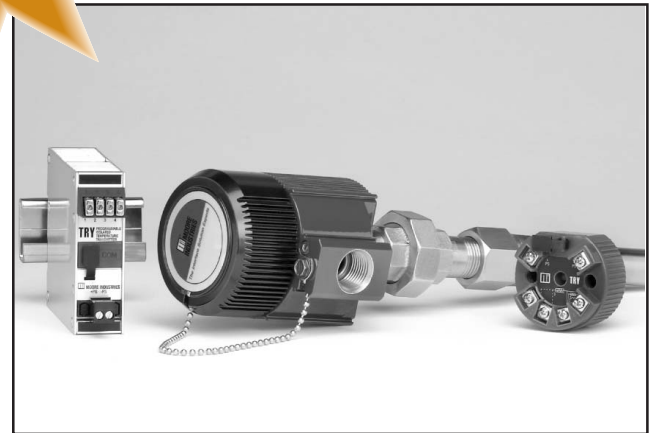
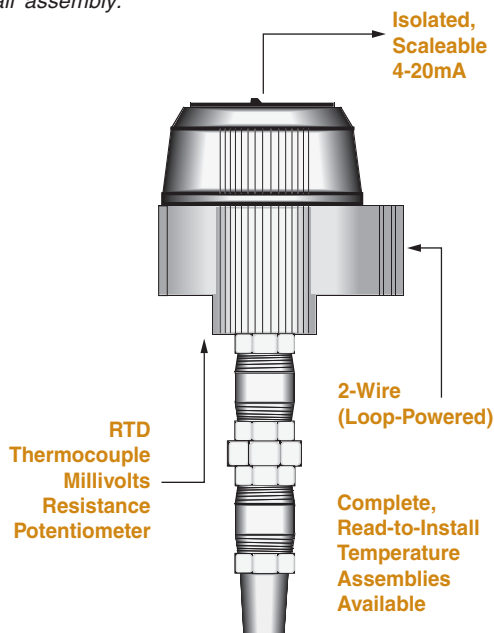

Available in a variety of housing styles, the TRY and TRX are ready to install in the control room, in existing hardware, or in their own, complete temperature assembly.

## Features

- **Universal plant standard.** No need to specify and stock fixed range transmitters as spares. The TRY and TRX provide programmable input type and output scaling.
- **PC-programmable with Windows® software.** From a single screen, you can choose, and then view to confirm, all of your application-specific operating parameters from a personal computer.
- **Fast measurement cycle.** Delivering an output update up to 8 times per second, these transmitters are twice as fast as comparable microprocessor-based instruments.
- **Enhanced configuration software.** Now trim input sensor readings, and customize input linearization curves for even greater accuracy. Program output damping to compensate for erratic sensor readings. Use the Configuration Program to calibrate other loop instruments with its innovative Loop Test function.

### Certifications



# TRY & TRX

PC-Programmable  
Temperature Transmitters

## Universal Solution

With the TRY & TRX, there's no need to specify and stock an array of single-function instruments. They are the perfect solution:

- Convert RTD, T/C, mV, and ohm signals to the linear 4-20mA needed by an indicator, recorder, PC, PLC, DCS, or similar SCADA system.
- Easily customize linearization to process inputs in non-linear, millivolt input applications.
- Trim input readings directly from sensors to achieve maximum relative accuracy. Match performance characteristics with your already-installed hardware.
- Avoid inaccuracies that result from transmitting "weak", low-level sensor signals through a noisy plant by converting them to stable, high-level signals that can withstand long-distance transmission.
- Use true, 4-wire RTD inputs to eliminate signal inaccuracies that result from inevitable lead wire resistance imbalances.
- Increase DCS accuracy by using transmitters calibrated to a specific temperature range in place of direct DCS inputs that are only capable of measuring readings over the entire range of a sensor.
- Reduce installation costs by replacing expensive and fragile sensor wire runs and costly DCS input cards.
- Compensate for erratic input signals with programmable damping values.

**Figure 2.** The TRY delivers complete isolation to stop ground loops from affecting signal accuracy.

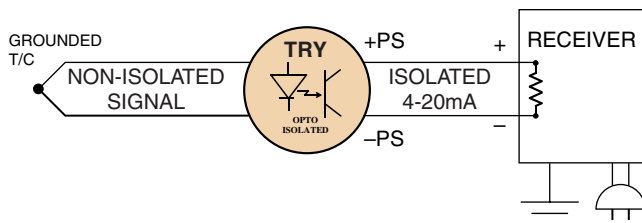

## Total Sensor Diagnostics

Our programmable transmitters perform continuous sensor diagnoses. This industry-first, and patented, Moore Industries feature may save you thousands in production costs, and hours of troubleshooting time, by letting you know when a problem occurs, and its type and location.

**Figure 3.** Total Sensor Diagnostics saves troubleshooting time.

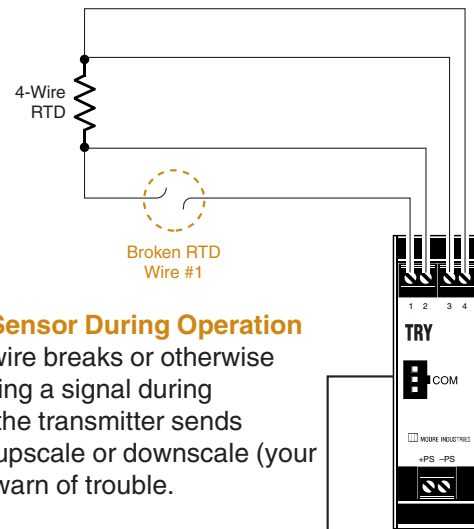

### Monitors Sensor During Operation

If an RTD wire breaks or otherwise stops sending a signal during operation, the transmitter sends the output upscale or downscale (your choice) to warn of trouble.

Then our transmitters go a step further. By connecting your PC running the TRY/TRX Configuration Software to the instrument, the RTD wire(s) causing the problem are identified via a plain-English error message on the software window. Specific error messages eliminate the work of removing the sensor or checking all lead wires to diagnose a problem. This advantage is especially valuable during startup.

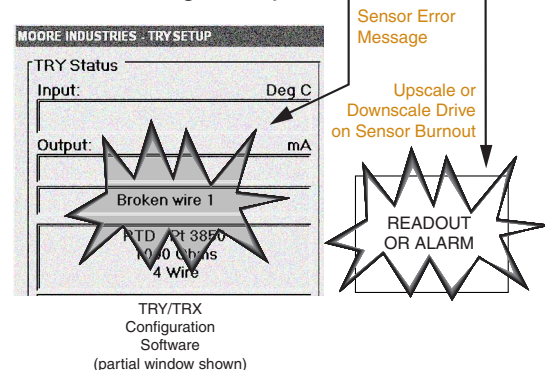

## Intelligent Configuration Software

Configuring the TRY & TRX is as simple as point-and-click. Improved linearization and trimming capabilities make it an even more valuable tool.

All you need is a PC running Windows®, our TRY/TRX Configuration Software and a Configuration Cable (software and cable supplied with each order).

In minutes, you can begin configuring your transmitter:

- Input type and range (zero and full scale)
- 4-20mA output range (zero and full scale)
- Reference junction compensation or no reference junction compensation for T/C inputs
- Linearization or no linearization
- Temperature readout in °F or °C
- 50Hz or 60Hz noise rejection
- Broken wire detection ON or OFF for calibration
- Upscale or downscale on sensor burnout
- Custom instrument tag (up to 40 characters) and instrument serial number
- Custom Input Linearization (up to 85 points)
- Custom Input Trimming to Actual Sensors
- Loop Test Fixed Output for Easy Calibration of other instruments in the Loop
- Damping Time for Erratic Signal Compensation (0-5 seconds)

Figure 4. All operating parameters can be set, and then viewed, on a single software screen.

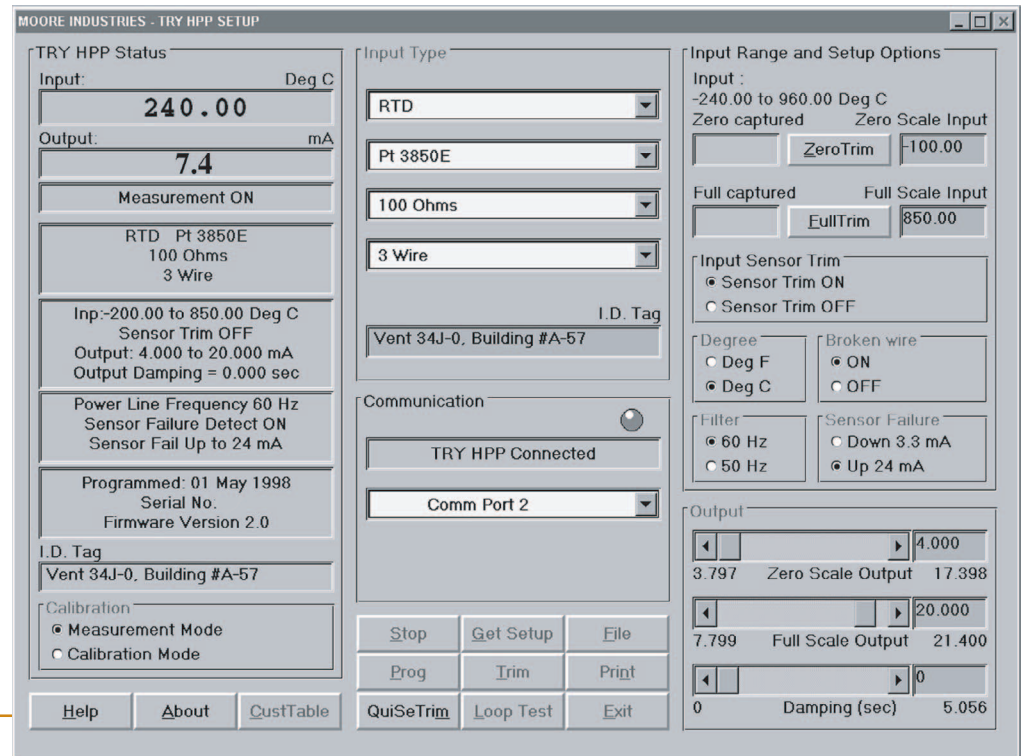

## Trim to Specific Curve Segments

The TRY & TRX can be trimmed with two data points within the selected zero and span measurement range. This allows a complete process range to be monitored, while placing measurement emphasis on a critical segment of the range.

In the figure below, the ideal RTD curve is optimized between 20°C and 27°C to match the curve of the sensor used. This provides incredible precision over a limited portion of span, while measuring the remainder of the span with outstanding accuracy.

Figure 5. The TRY & TRX can be set to measure the segment most critical to the process.

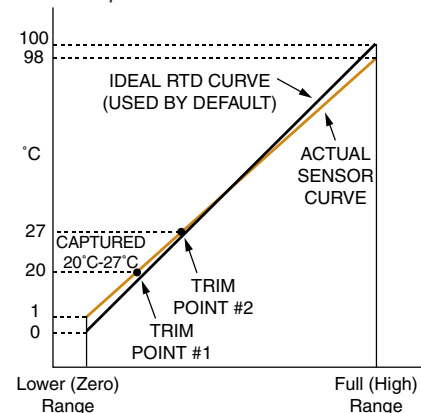

# TRY & TRX

PC-Programmable  
Temperature Transmitters

## Specifications

**Performance** **Input Accuracy:**  
Refer to Table 1  
**Output Accuracy:**  
±0.03% of input span  
setting + input accuracy  
**Reference Junction  
Compensation Accuracy:**  
±0.45°C  
**Stability:** Error is in % of  
conformance range:  
T/C and mV: 0.11% for 1  
year; 0.18% for 3 years;  
0.24% for 5 years.  
RTD, Ohms and  
Potentiometer: 0.13% for 1  
year; 0.22% for 3 years;  
0.28% for 5 years.  
**Isolation:** For TRY in HPP  
housing, 1500Vrms input  
to output; for TRY in DIN  
housing, 500Vrms input to  
output to case  
**Measurement Cycle:**  
Output updates 8 times per  
second  
**Output Response:**  
256msec, maximum, for  
output to reach full scale in  
response to a 10-90% step  
change on input  
Output updates 8 times per  
second  
**Linearity:** 0.1% of span,  
within rated ranges  
**Ripple:**  
10mVp-p, maximum  
**Power Supply and Load  
Effect:** Negligible within  
power and load limits

**Performance (continued)** **Over-Voltage Protection:**  
4V, maximum, on input;  
48V, maximum on output;  
48V reverse polarity  
protection on output  
**Load Capability:**  
500 ohms@24V, typical:  
TRY resistance = (Supply  
Voltage - 10V) ÷ 0.024A;  
TRX resistance = (Supply  
Voltage - 8V) ÷ 0.024A  
**Burnout Protection:**  
Total Sensor Diagnostics  
are user-selected via  
Windows®-based  
configuration software;  
Upscale to 24mA or  
Downscale to 3.3mA  
**Output Current  
Limiting:** 21.4mA for  
input over-range; 23.6mA  
for sensor failure or  
broken wire  
**T/C Input Impedance:**  
40 Mohms, nominal  
**RTD Excitation:**  
250 microamps, ±10%  
**RTD Lead Wire  
Resistance Maximum:**  
RTD resistance + 2 times  
the lead wire resistance  
must be less than 4000  
ohms; recommend <35  
ohms per wire for 3-wire  
RTD inputs; <5 ohms per  
wire for 10 ohm Cu inputs

**Ambient Operating and Storage  
Conditions Range:** -40°C to +85°C  
(-40°F to +185°F)

**Ambient Relative Humidity:  
Conditions** 0-95%, non-condensing  
**(Continued)** **Effect of Ambient  
Temperature on  
Accuracy:** ±0.015% of  
span per °C change,  
maximum (+ 0.001% of  
resistance reading for RTD  
inputs)  
**Effect of Ambient  
Temperature on  
Reference Junction  
Compensation:**  
±0.015°C /°C change  
**RFI/EMI Immunity:**  
20V/M@20-1000MHz,  
when tested according to  
SAMA standard 33.1.  
(10V/m@80-1000MHz,  
1kHz AM, when tested  
according to IEC 1000-4-3-  
1995)  
**Noise Rejection:**  
COMMON MODE:  
100dB, minimum,  
@ 50/60Hz;  
NORMAL MODE: 100dB,  
typical, @ 1Vp-p, 50/60Hz

**Adjustments** All settings made using our  
Windows®-based  
configuration program,  
then stored in non-volatile  
memory

**Weight** **HPP housing:** 65g  
(2.3 oz)  
**DIN housing:** 184g  
(6.5 oz)  
**LH housing:** 549g  
(19.4 oz)

### Certifications



#### Factory Mutual Approvals

**Intrinsically Safe – HPP:**  
Class I, II, III, Division 1, Groups A, B, C, D, E, F, G  
**Non-Incendive – HPP:**  
Class I, Division 2, Groups A, B, C, D  
**Suitable for:**  
Class II, Division 2, Groups F and G  
Class III, Division 2

**Explosion/Dust Ignition-Proof†** – [HPP in LH2]:  
Class I, Division 1, Groups A\*, B, C, D  
Class II and III, Division 1, Groups E, F, G  
T6@60°C Maximum Ambient; NEMA 4X; IP66



#### Canadian Standards Association (CSA)

**Intrinsically Safe – HPP:**  
Class I, Division 1, Groups A, B, C, D  
**Non-Incendive – HPP:**  
Class I, Division 2, Groups A, B, C, D  
**General (Ordinary) Location – DIN/HPP**



#### European/ATEX 94/9/EC Directive Approvals:

**ISSEp Flame-Proof Apparatus – [HPP in LH2]**  
⊕ II 2GD EEx d IIC T6, IP66

**LCIE Intrinsically Safe Apparatus – [HPP]**  
⊕ II 2G EEx ib IIB/IIC T6@60°C



**TestSafe Flame-Proof Approvals – [HPP in LH2]**  
Ex d IIC; T6@60°C



**CE Conformant – EMC Directive 89/336/EEC**  
EN 61326

\* For Group A only, all conduits must be sealed within 18 inches  
† 60°C (140°F) Maximum Ambient Temperature

## Ordering Information

| Unit  | Input  | Output   | Power  | Options   | Housing  |
|---|--|--|--|---|--|
| <b>TRY</b><br>Isolated,<br>PC-Program-<br>mable<br>Temperature<br>Transmitter     | <b>PRG</b><br>Program-<br>mable with<br>supplied<br>Configuration<br>Software<br>(see Table 1<br>for descrip-<br>tions of<br>available<br>input types;<br>Factory<br>Configuration<br>available) | <b>4-20MA</b><br>User<br>scaleable<br>with<br>supplied<br>software | <b>10-42DC</b><br><b>10-30DC</b><br>Required<br>for -ISC,<br>-ISE and<br>-ISF<br>options | <b>-ISC</b> CSA<br>approved IS<br>and NI (HPP)<br><b>-ISE</b> ATEX<br>approved IS<br>(HPP)<br><b>-ISF</b> FM<br>approved IS<br>and NI (HPP)<br><b>-FMEDA</b> Unit<br>comes with<br>Failure Modes,<br>Effects and<br>Diagnostic<br>Analysis<br>(FMEDA) data<br>for evaluating<br>the instrument<br>for suitability of<br>use in a<br>safety-related<br>application | <b>DIN</b> DIN-style aluminum housing mounts on 32mm G-type (EN50035) and 35mm Top Hat (EN50022) rails<br><b>HPP</b> Hockey-puck housing for mounting in standard connection heads<br><b>LH1NS*</b> Connection head (FM approved, NEMA 4X, IP66) with two entry ports: ½-inch NPT cable and process-black PBT polyester cover<br><b>LH1MS*</b> Connection head (FM approved, NEMA 4X, IP66) with two entry ports: M20 cable and ½-inch NPT process-black PBT polyester cover<br><b>LH1CS*</b> Connection head with two entry ports: M20 cable and G½ (BSP) process-black PBT polyester cover<br><b>LH1NX</b> Connection head with ½NPT entry and mounting plate for customer's air duct opening-black PBT polyester cover<br><b>LH2NS*‡</b> Explosion-proof connection head (FM approved, Class I, Div 1, Groups A**,B,C,D; Class II, Groups E,F,G; Class III) with two entry ports: ½-inch NPT cable and process-black metal cover<br><b>LH2MS*‡</b> Explosion-proof connection head (FM approved, Class I, Div 1, Groups A**,B,C,D; Class II, Groups E,F,G; Class III) with two entry ports: M20 cable and ½-inch NPT process-black metal cover<br><b>CH6</b> Plastic connection head<br><b>CH17</b> CSA & UL approved explosion-proof housing for use in Class I, Div 1, Groups A,B,C,D; Class II, Groups E,F,G; Class III<br><br><b>A</b> suffix indicates SAA/TestSafe (Ex d) Flame-Proof approvals (i.e. LH2NSA)<br><b>E</b> suffix indicates ATEX (EEx d) Flame-Proof approvals (i.e. LH2NSE)<br><b>P</b> suffix indicates enclosure comes equipped with base plate and U-bolts for mounting on a 2-inch pipe (i.e. LH1NSP)<br><br>** For Group A (only) all conduits must be sealed within 18 inches.<br><br>‡ LH2 Explosion-proof certification carries 60°C (140°F) max ambient temperature restriction.<br><br>Other connection heads, cabinets, and enclosures also available.<br>Ask your Interface Solutions Expert for details. |
| <b>TRX</b><br>Non-Isolated,<br>PC-Program-<br>mable<br>Temperature<br>Transmitter | <b>PRG</b><br>Program-<br>mable with<br>supplied<br>Configuration<br>Software<br>(see Table 1<br>for descrip-<br>tions of<br>available<br>input types;<br>Factory<br>Configuration<br>available) | <b>4-20MA</b><br>User<br>scaleable<br>with<br>supplied<br>software | <b>8-42DC</b><br><b>8-30DC</b><br>Required<br>for -ISC,<br>-ISE,<br>and -ISF<br>options  |   |  |

**When Ordering, specify:** Unit/Input/Output/Power/Option(s) [Housing]

**Model number example:** TRY/PRG/4-20MA/10-30DC/-ISF [LH2MSP]

**NOTE:**

Factory Mutual (FM) certifications apply to the transmitter (TRY or TRX) and the LH2NS and LH2MS connection head combination ONLY. Sensor, thermowell or fixed immersion sensor components are not included in the certifications.

### Everything You Need is Included...

Each TRY and TRX order comes with one copy of our Configuration Software (Windows® compatible) on CD and one non-isolated configuration cable.

To order additional software or cables:

| Part Number  | Part                                  |
|--------------|---------------------------------------|
| 750-75E05-01 | Intelligent PC Configuration Software |
| 803-039-26   | Isolated Configuration Cable          |
| 803-040-26   | Non-Isolated Configuration Cable      |

# TRY & TRX

PC-Programmable  
Temperature Transmitters

Table 1. TRY & TRX Input and Accuracy Table

| Input      | Type                                  | $\alpha^*$ | Ohms                             | Conformance Range                  | Minimum Span                      | Input Accuracy**                                    | Maximum Range                      |                                   |
|------------|---------------------------------------|------------|----------------------------------|------------------------------------|-----------------------------------|---|------------------------------------|-----------------------------------|
| RTD        | Platinum                              | 0.003750   | 1000                             | -50 to 500°C<br>-58 to 932°F       | 15°C (27°F) for<br>100 ohm inputs | ±0.11°C ±0.2°F                                      | -100 to 560°C<br>-148 to 1040°F    |                                   |
|            |                                       | 0.003850   | 100, 200, 300,<br>400, 500, 1000 | -200 to 850°C<br>-328 to 1562°F    |                                   | ±0.21°C ±0.38°F                                     | -240 to 960°C<br>-400 to 1760°F    |                                   |
|            |                                       | 0.003902   | 100, 200, 400<br>500, 1000       | -100 to 650°C<br>-148 to 1202°F    |                                   | ±0.15°C ±0.27°F                                     | -150 to 720°C<br>-238 to 1328°F    |                                   |
|            |                                       | 0.003911   | 100, 500                         | -200 to 630°C<br>-328 to 1166°F    |                                   | ±0.17°C ±0.31°F                                     | -235 to 710°C<br>-391 to 1310°F    |                                   |
|            |                                       | 0.003916   | 100                              | -200 to 510°C<br>-328 to 950°F     |                                   | 7.5°C (13.5°F)<br>for 500 and<br>1000 ohm<br>inputs | ±0.14°C ±0.25°F                    | -240 to 580°C<br>-400 to 1076°F   |
|            |                                       | 0.003923   | 98.129                           | -200 to 600°C<br>-328 to 1112°F    |                                   |   | ±0.16°C ±0.29°F                    | -235 to 680°C<br>-391 to 1256°F   |
|            |                                       | 0.003926   | 100, 470,<br>500                 | -200 to 630°C<br>-328 to 1166°F    |                                   |   | ±0.17°C ±0.31°F                    | -235 to 710°C<br>-391 to 1310°F   |
|            |                                       | 0.003928   | 100                              | -200 to 850°C<br>-328 to 1562°F    |                                   |   | ±0.21°C ±0.38°F                    | -260 to 962°C<br>-436 to 1763.6°F |
|            | Nickel                                | 0.000672   | 120                              | -80 to 320°C<br>-112 to 608°F      | 10°C (18°F)                       | ±0.16°C ±0.29°F                                     | -100 to 360°C<br>-148 to 680°F     |                                   |
|            | Copper                                | 0.000427   | 9.035                            | -50 to 250°C<br>-58 to 482°F       | 100°C (180°F)                     | ±1.2°C ±2.16°F                                      | -65 to 280°C<br>-85 to 536°F       |                                   |
| Ohms       | Direct resistance<br>or Potentiometer | n/a        | n/a                              | 0-4000 ohms                        | 30 ohms                           | ±0.4 ohms   | n/a                                |                                   |
| T/C        | J                                     | n/a        | n/a                              | -180 to 770°C<br>-292 to 1418°F    | 35°C<br>63°F                      | ±0.28°C ±0.5°F                                      | -210 to 770°C<br>-346 to 1418°F    |                                   |
|            |                                       | n/a        | n/a                              | -150 to 1372°C<br>-238 to 2501.6°F | 40°C<br>72°F                      | ±0.3°C ±0.54°F                                      | -270 to 1390°C<br>-454 to 2534°F   |                                   |
|            |                                       | n/a        | n/a                              | -170 to 1000°C<br>-274 to 1832°F   | 35°C<br>63°F                      | ±0.26°C ±0.47°F                                     | -270 to 1013°C<br>-454 to 1855.4°F |                                   |
|            |                                       | n/a        | n/a                              | -200 to 400°C<br>-328 to 752°F     | 20°C<br>36°F                      | ±0.24°C ±0.43°F                                     | -270 to 407°C<br>-454 to 764.6°F   |                                   |
|            |                                       | n/a        | n/a                              | 0 to 1768°C<br>32 to 3214.4°F      | 50°C<br>90°F                      | ±0.71°C ±1.28°F                                     | -50 to 1786°C<br>-58 to 3246.8°F   |                                   |
|            |                                       | n/a        | n/a                              | 0 to 1768°C<br>32 to 3214.4°F      | 50°C<br>90°F                      | ±0.71°C ±1.28°F                                     | -50 to 1786°C<br>-58 to 3246.8°F   |                                   |
|            |                                       | n/a        | n/a                              | 400 to 1820°C<br>752 to 3308°F     | 75°C<br>135°F                     | ±0.43°C ±0.77°F                                     | 200 to 1836°C<br>392 to 3336.8°F   |                                   |
|            |                                       | n/a        | n/a                              | -130 to 1300°C<br>-202 to 2372°F   | 45°C<br>81°F                      | ±1.33°C ±2.39°F                                     | -270 to 1316°C<br>-454 to 2400.8°F |                                   |
|            |                                       | n/a        | n/a                              | 0 to 2315°C<br>32 to 4199°F        | 100°C<br>180°F                    | ±1.16°C ±2.09°F                                     | 0 to 2338°C<br>32 to 4240.4°F      |                                   |
| Millivolts | DC                                    | n/a        | n/a                              | -50 to 1000mV                      | 4mV                               | ±0.04mV   | -50 to 1000mV                      |                                   |

\*  $\alpha$  values with both 32 and 128-point linearization curves are available. (Lower resolution values provided for compatibility with older units.)

\*\*Accuracy ratings are expressed as a percent of the total conformance range, at spans larger than recommended minimums. (Accuracy ratings for RTD inputs apply at 25°C)

**Figure 6.** The DIN-style TRY is ideal for Control Room or Cabinet Installations.

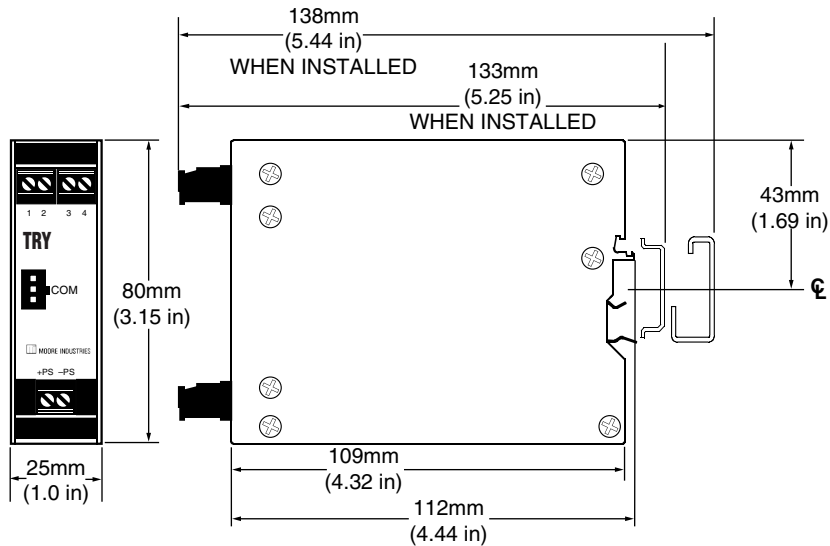

**Figure 7.** Use the HPP-Style Hockey-Puck Housing for Installation in Field Enclosures.

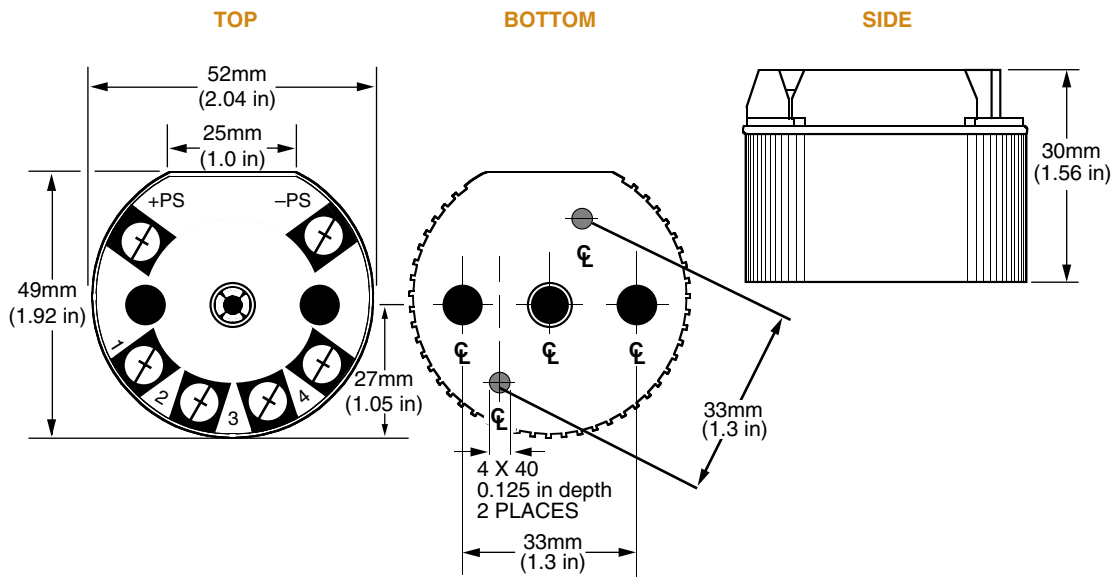

**Figure 8.** Connecting an Input to the TRY/TRX.

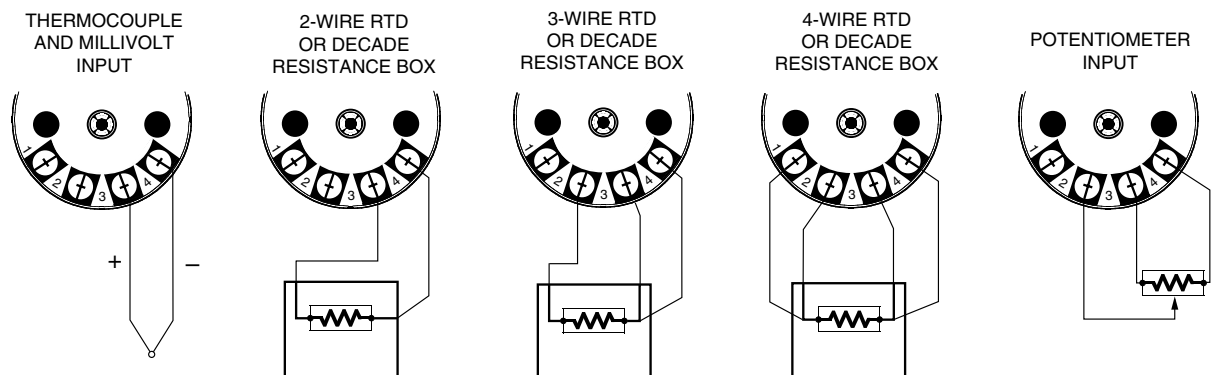

# TRY & TRX

PC-Programmable  
Temperature Transmitters

Figure 9. The TRY and TRX Feature Rugged, Fully Certified, Ready-to-Install Housing Styles.

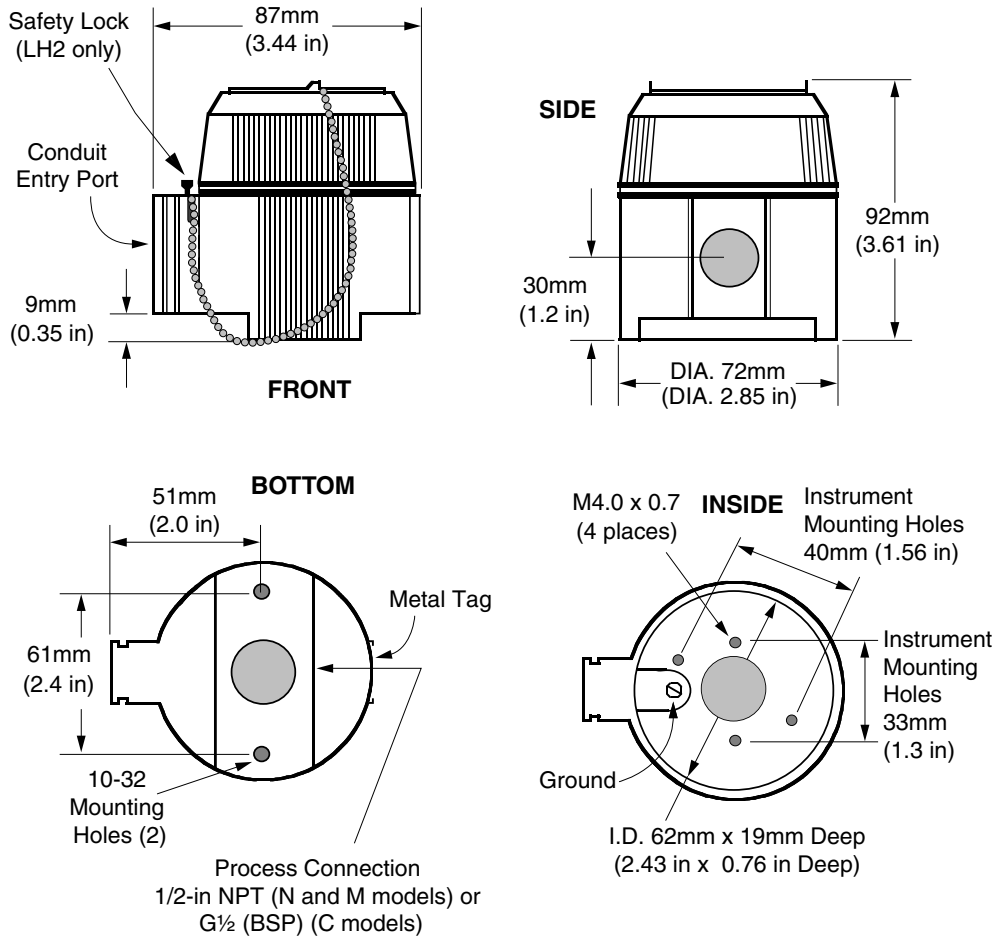

## 2-INCH PIPE MOUNTING HARDWARE

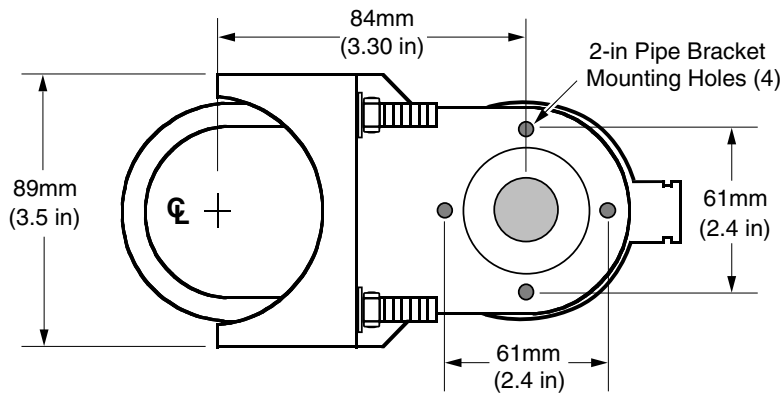

United States • info@miinet.com  
Tel: (818) 894-7111 • FAX: (818) 891-2816  
Australia • sales@mooreind.com.au  
Tel: (02) 8536-7200 • FAX: (02) 9525-7296

Belgium • info@mooreind.be  
Tel: 03/448.10.18 • FAX: 03/440.17.97  
The Netherlands • sales@mooreind.nl  
Tel: (0)344-617971 • FAX: (0)344-615920

China • sales@mooreind.sh.cn  
Tel: 86-21-62481120 • FAX: 86-21-62490635  
United Kingdom • sales@mooreind.com  
Tel: 01293 514488 • FAX: 01293 536852