



## Description

Moore Industries' Smart HART® Temperature Transmitters configure in minutes to accept a direct signal input from nearly every available RTD and thermocouple, as well as from ohm and mV sources. Universal and microprocessor-based, they provide an isolated and linear 4-20mA output proportional to the input. This signal is ready for direct interface with HART or non-HART based DCS, PLC and other computer-based SCADA systems.

### Easy-to-Order Temperature Assemblies

One simple model number is all it takes to order our complete temperature assemblies. They come configured, calibrated, wired and ready to install in your process. **See our RTI1 and RTI2 Ready-to-Install Temperature Transmitter Assemblies data sheets for details.**

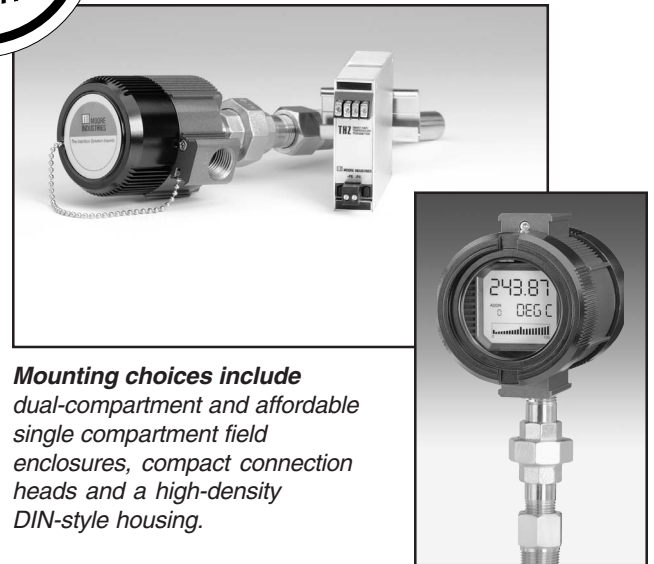

**Mounting choices include** dual-compartment and affordable single compartment field enclosures, compact connection heads and a high-density DIN-style housing.

## Features

- **Input-to-output analog accuracy of up to  $\pm 0.014^{\circ}\text{C}$  ( $\pm 0.025^{\circ}\text{F}$ )\*** is the absolute best in the industry.
- **20-bit input resolution delivers exceptional digital accuracy of  $\pm 0.1^{\circ}\text{C}$  ( $\pm 0.18^{\circ}\text{F}$ )** with all Pt RTDs, or up to  $\pm 0.05^{\circ}\text{C}$  ( $\pm 0.09^{\circ}\text{F}$ )\* for Pt1000 RTD.
- **Set up with HART Communicator, HART-based system, or PC** allows you to check the status, or perform parameter changes, from the control room or any field termination point on the 4-20mA wires.
- **Long-term stability** provides up to 5 years between scheduled calibrations.
- **Standard integral displays show real-time process status** and valuable loop diagnostic information.
- **Advanced EMI/RFI protection and ambient temperature compensation** guard against environmental factors that can quickly degrade measurement accuracy.
- **PC software's "HelpMap Navigation System"** provides quick and complete answers to performance, setup, installation and maintenance questions.

**Figure 1.** Universal, programmable input with a fully isolated and linear analog output.

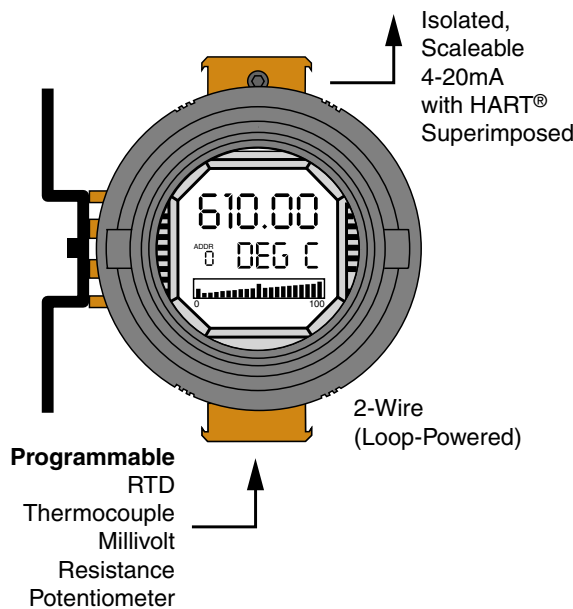

### Certifications



All product names are registered trademarks of their respective companies. HART is a registered trademark of the HART Communication Foundation.



# THZ & TDZ

Smart HART®

Temperature Transmitters

## Set Up with HART Communicator, DCS, Asset Management System (AMS) or PC

Our Smart HART Transmitters can be programmed in minutes and interrogated at any time, from anywhere on the 4-20mA loop (see Figure 2). You can use a standard hand-held HART Communicator (such as a Model 275), a HART-based control system, an Asset Management System (AMS) or Moore Industries' Intelligent PC Configuration Software to:

- **Program Input Type and Range**—Span, zero and input type values are all programmable.
- **Adjust Sensor Trim Offset**—Set an offset to compensate for measurement errors that are caused when a temperature sensor is not performing to its rated curve specifications.
- **Set Damping Time**—Eliminate imprecise readings caused by noise and other insignificant process fluctuations by setting a damping time between 1-30 seconds.
- **View Real-Time Process Values**—View the existing process value (in the appropriate engineering unit), lower and upper range values, actual output current and output current as a percentage of output span.

- **Choose Sensor Failure Mode**—If the input is lost, you have the choice of the output going upscale (to 23.6mA) or downscale (to 3.6mA).
- **Select Device Identification and Data**—Tag number (8 characters), configuration date, unit location code (16 characters), a message (32 characters), and polling address (0-15) are selectable.
- **Fix Output Current (Loop Test)**—To assist in calibrating your system, the THZ's and TDZ's current output can be fixed to a known value so you can check it against the value being read by your receiving device.

### Non-Volatile Memory

If power to the transmitter is lost, the unit resumes normal operation with the parameters you've configured upon reapplication of power.

### Point-to-Point Loops Deliver Analog Simplicity with Remote Programmability

In the majority of applications, the THZ or TDZ is installed on a point-to-point 4-20mA process loop like a regular analog transmitter (Figure 2). A HART Communicator or HART-based system is used to configure and view the transmitter's operating parameters and diagnostic data from any point on the loop.

**Figure 2.** From any point on the 4-20mA loop, you can view, test and change your transmitter's operating parameters.

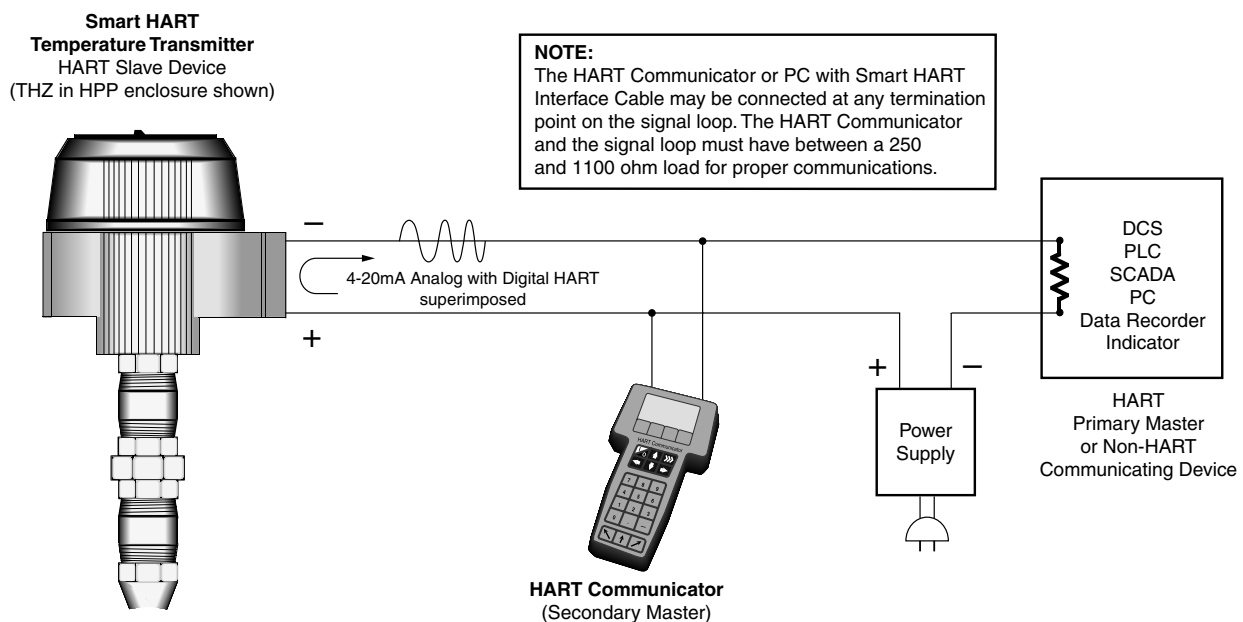

**Figure 3.** Save time and money by networking up to 15 of our smart transmitters onto a single digital data link.

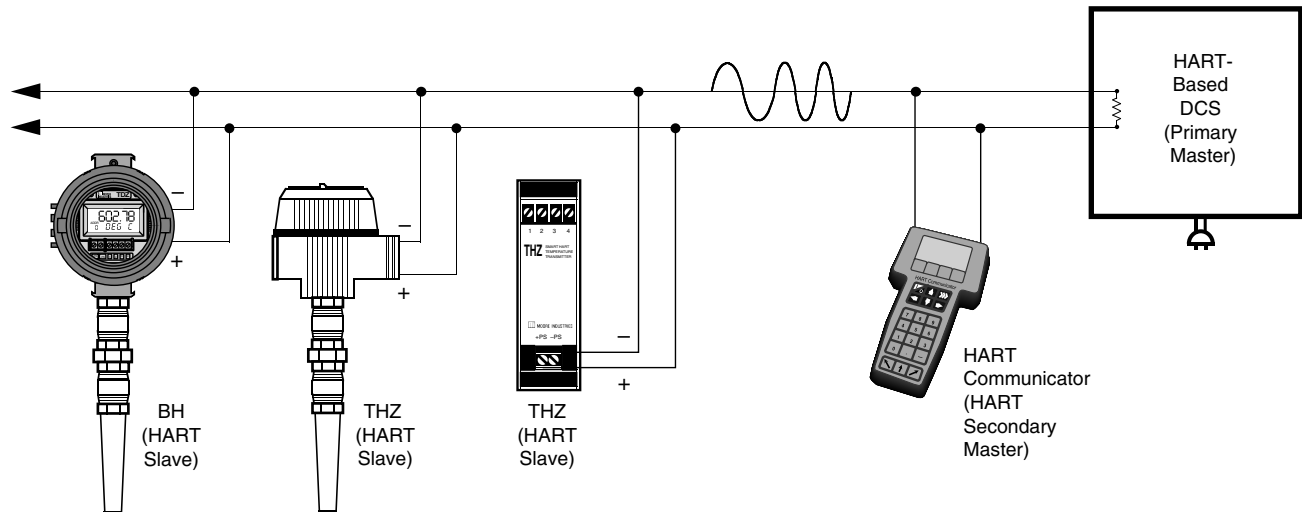

### Multidrop Networks Save Wiring Costs

Any combination of up to 15 THZ and TDZ smart transmitters connect in parallel onto a HART digital communication link (Figure 3). This means you can use a single loop, instead of 15 separate loops, to connect multiple transmitters. In a multidrop network, the transmitter's measured process variable is output digitally, so the 4-20mA signal (set to 4mA) is not used.

A HART-based control system uses each transmitter's individual address (1-15) to configure or view the transmitter's data. A HART Communicator can be used in this configuration to access information from, or transmit configuration information to the transmitter from anywhere on the HART loop.

### HART Master/Slave Structure

To implement two-way communications between the THZ or TDZ and the device configuring or receiving its information, the transmitter operates in a HART Master/Slave structure.

The THZ or TDZ is a Slave (or Slaves in a multidrop network). There can be two Masters per system: a Primary Master and a Secondary Master. In the majority of applications, the Master is a HART Hand-Held Communicator, but it can also be a HART-based control system. Operating in HART's Poll/Response (Normal) Mode, the HART Master polls the THZ or TDZ two times per second to access the current process variable status, send setup data to the transmitter, or remotely view its identification, configuration and diagnostic data.

### THZ & TDZ Device Description (DD)

Moore Industries' Device Description (DD) is the device-specific programming information that is loaded into a standard HART Communicator (such as the Model 275). It allows access to all of the unit's programming functions except the custom linearization table function. The THZ/TDZ DD is available on the HART Communication Foundation's October 1999 and later Device Driver Library release. We can update your Model 275 or configure your transmitter at any of our solution centers.

### How to Determine if Your HART Communicator Has a THZ & TDZ Device Driver

To determine if your HART Communicator has the DD, press "1" to select "Offline" and press "1" again to select "New Configuration". Select "Moore Industries" from the list of companies. The "THZ/TDZ" option will appear if you have the proper DD installed. To update your HART communicator with the latest DD, call our Interface Solution Center nearest you.

### Also Programs with the Generic HART DD

Even if your communicator is not up to date, most of the important programming features can be accessed without the THZ/TDZ DD by using the "Generic" HART DD available on HART Communicators. Or you can order the unit factory-configured by Moore Industries with all of the parameters that are not accessible through the generic DD.

# THZ & TDZ

Smart HART®

Temperature Transmitters

## Easy-to-Read, Customizable Display

THZ [DH enclosure] and TDZ transmitters come standard with a large display that features easy-to-read alphanumeric characters. Set the display to show input status, output status or toggle between both. They can even be custom-scaled to display an engineering unit of your choice (Figure 4).

**Figure 4.** Standard process display shows input, output or toggles intermittently between the two.

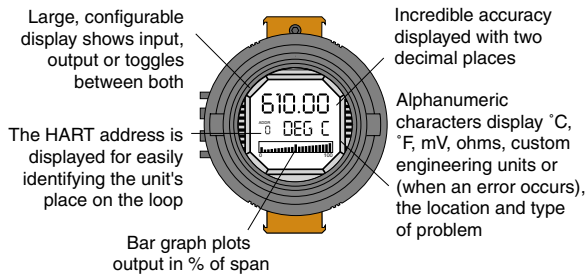

## Total Sensor Diagnostics

These transmitters perform continuous sensor diagnostics. This patented Moore Industries feature can save you from costly lost production time and hours of troubleshooting. If the sensor breaks or otherwise stops sending a signal during operation, the transmitter sends the output upscale or downscale to warn of trouble, and provides a HART digital error message that can be read by a HART communicator or computer-based system. If the sensor being utilized is a RTD, the THZ or TDZ instantly displays the type and location of the error.

**Figure 5.** Total Sensor Diagnostics saves troubleshooting time.

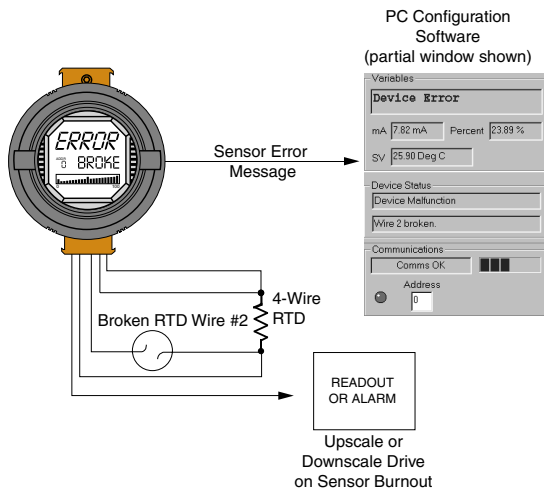

## Trims to Respond to Specific Sensor Curve Segments

Most transmitter's zero and span values can be calibrated to measure a specific range within a sensor's overall curve capability. However, for even greater measurement accuracy, our transmitters trim capabilities go much further.

The THZ and TDZ can be trimmed with two data points within the selected zero and span measurement range. This advantage allows a complete process range to be monitored, while placing measurement emphasis on a specific segment of the range most critical to the process.

In the figure below, the actual sensor curve is used in place of the ideal RTD curve between 20°C and 27°C. This provides incredible precision over a limited portion of span, while measuring the remainder of the span with the THZ or TDZ's usual outstanding accuracy.

**Figure 6.** The THZ and TDZ can be set to measure the segment most critical to the process.

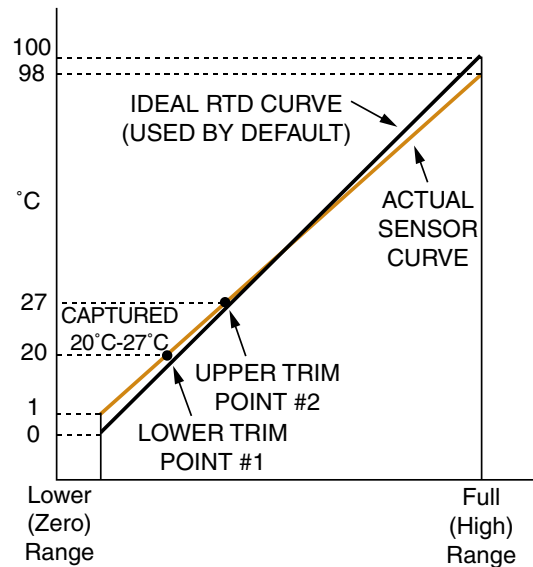

## Precise Linearization and RJC

The THZ and TDZ use an advanced linearization method to minimize the conformance error. Its Reference (Cold) Junction Compensation techniques produce stable readings even in fluctuating ambient temperature conditions. For non-linear inputs, create custom linearization curves using our PC Configuration Software.

## One Window. One Minute. One Set Up.

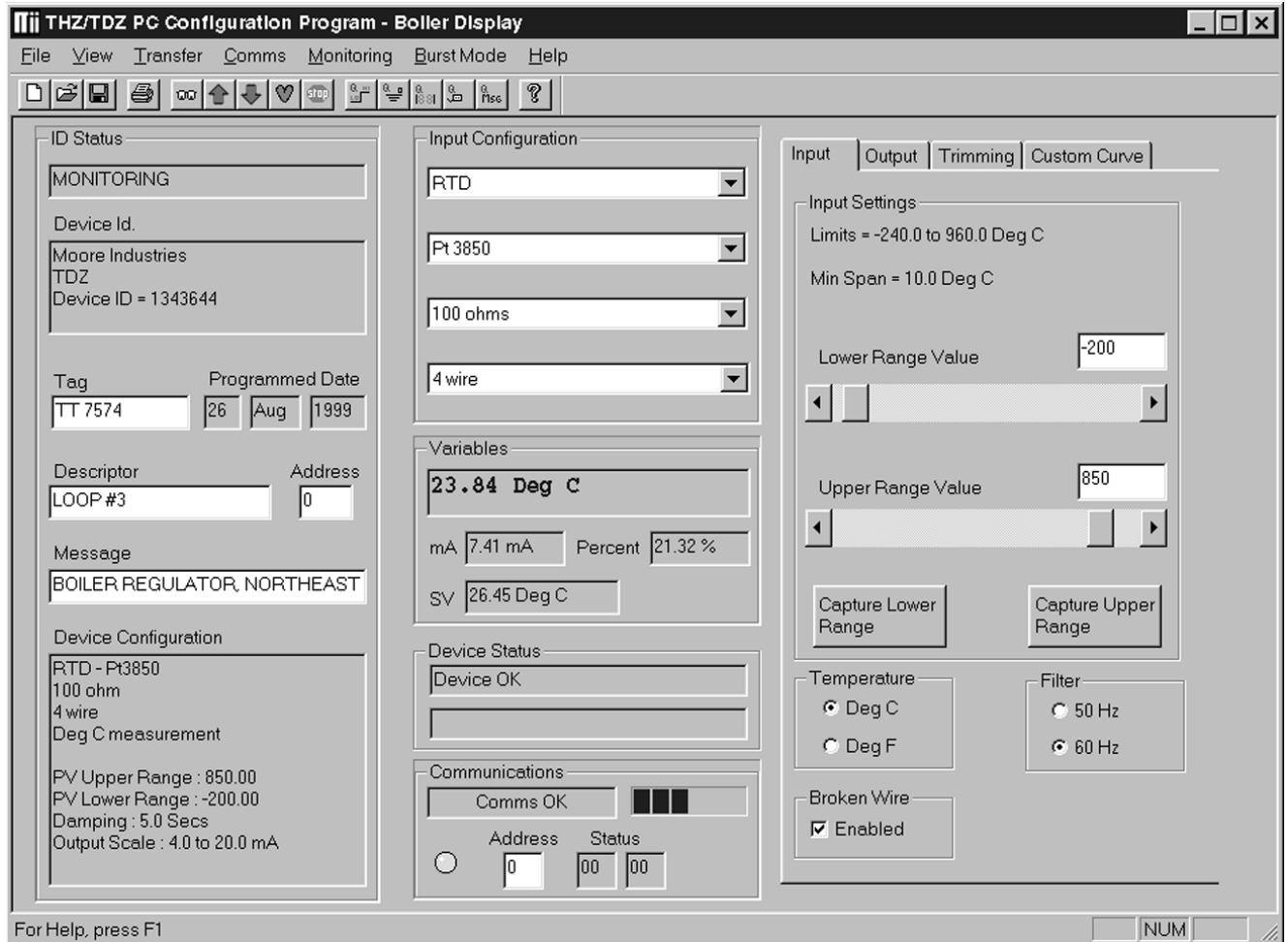

### Intelligent PC Configuration Software

Our Intelligent PC Configuration software allows you (with the aid of our HART-to-RS232 Smart Interface Cable) to set up all your transmitter's settings from just one window, in about a minute. Once a set up is created, it can be downloaded to multiple transmitters. Just a few of the time saving and performance enhancing features include:

**Set Up Safeguards**—It is nearly impossible to make incompatible configuration selections.

**Transmitter/Configuration Auto Recognition**—The program software automatically recognizes the transmitter model and its configuration parameters.

**Toolbar for Frequently Used Commands**—A conveniently located toolbar provides quick access to often used configuration functions.

**Real-Time Process Readout**—The process measurement and the communication status between the transmitter and PC is continually shown on the software window.

**Precise Digital Output Trimming**—This essentially eliminates the impact of measurement errors introduced by inaccurate readout devices.

**Selectable Under Range, Over Range and Sensor Failure Values**—By setting different default values for each condition, you can distinguish between the failure modes when they occur.

**Store and Print Files**—The configuration record you've created may be downloaded to any number of transmitters, stored for recordkeeping or printed.

# THZ & TDZ

Smart HART®

Temperature Transmitters

## HelpMap Navigation System

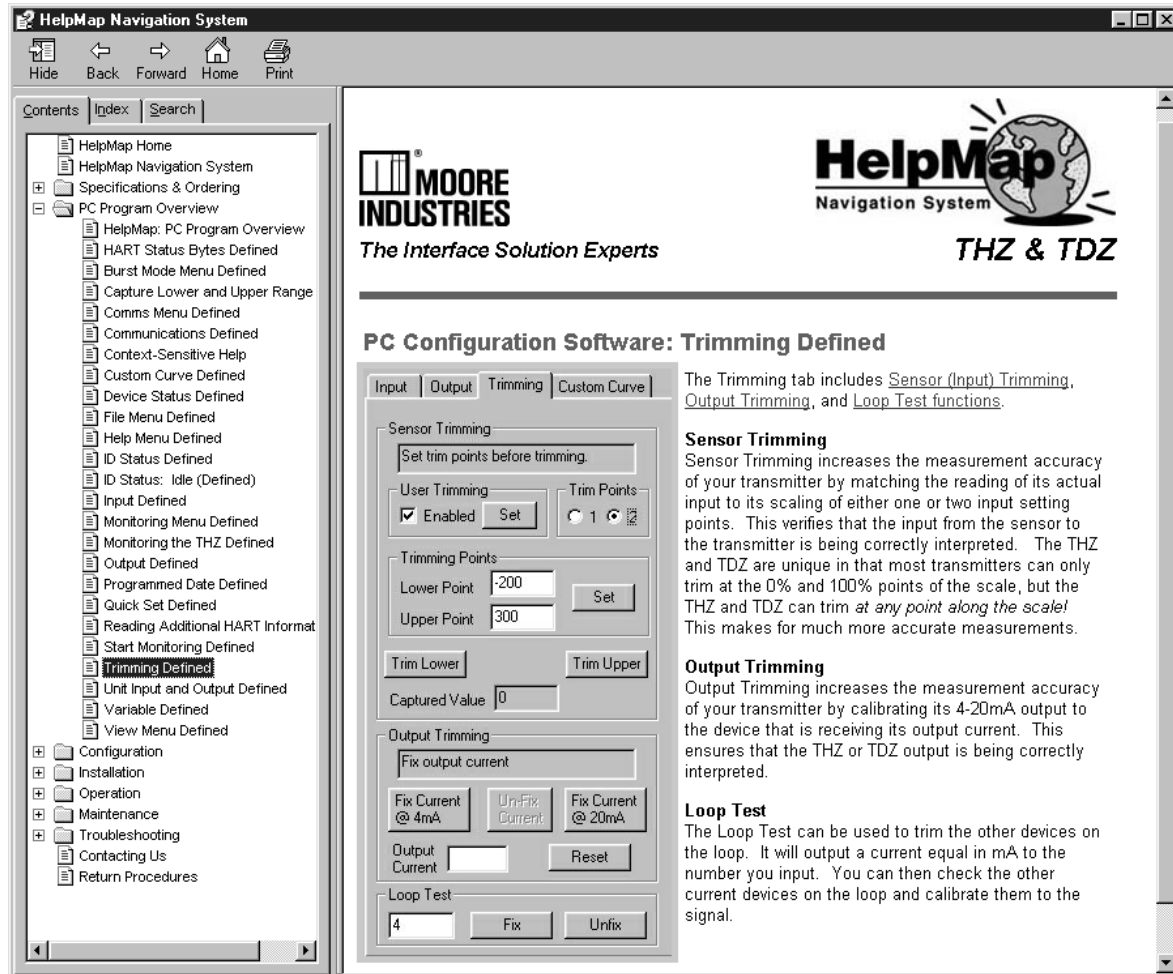

### Guides You From Hook-Up to Start-Up

Just click the Help icon on the toolbar of our Intelligent PC Configuration Software, and up pops **HelpMap**, our searchable help system. It smoothly guides you from hook-up to start-up.

**Easy to Use**—The revolutionary HelpMap system is remarkably intuitive. Based on the programming language used to design Internet web pages, it has all the functions you would expect from a high-powered help system with the ease and functionality of a web site.

**In-Depth Explanations**—The HelpMap is packed with overviews of specific features as well as step-by-step directions on how to configure, install, maintain and troubleshoot your transmitter.

**Intuitive Imagemaps**—Point and click your way to any definition by using a picture of the Configuration Software from inside the HelpMap System. Just click on the part of the image that you need more information about.

**Advanced Search Features**—Our advanced search engine will search word-for-word through the help file to quickly find the necessary information. Combine this search engine with a complete index, and all the information for using the transmitter is available at your fingertips.

**Context-Sensitive Help**—Need a quick definition? Concise information and software definitions regarding the part of the program you are using are available from our context-sensitive help system.

## Specifications

<p><b>HART Specifications</b></p> <p><b>Address Range:</b> 0-15 (1-15 are for multidrop loops)</p> <p><b>Transmission Speed:</b> 1200 baud</p> <p><b>Character Format:</b> 1 Start Bit - 8 Data Bits - 1 Odd Parity Bit - 1 Stop Bit</p>	<p><b>Performance (Continued)</b></p> <p><b>Response (Rise) Time:</b> 100msec maximum for the output to change from 10% to 90% for an input step change of 0% to 100%</p> <p><b>Step Response Time:</b> THZ: 600msec maximum, 500msec typical from the time an input is applied to the output reaching 90% of its final value THZ in DH Enclosure &amp; TDZ (all models): 700msec maximum, 500msec typical from the time input is applied to the output reaching 90% of its final value</p> <p><b>Ripple:</b> Less than 10mVp-p measured across a 250 ohm load resistor at frequencies up to 120Hz</p> <p><b>Over-voltage Protection:</b> Input, ±5Vdc peak, maximum; Output, 48Vdc, maximum</p> <p><b>Digital Input Filter:</b> User-programmable; 50/60Hz</p> <p><b>Power Supply Effect:</b> ±0.002% of span per 1V change</p> <p><b>Load Effect:</b> Negligible within specified power limits</p> <p><b>Load Capability:</b> <math>Load = \frac{(V_{dc} - 12)}{0.024}</math></p>	<p><b>Performance (Continued)</b></p> <p><b>Burnout Protection:</b> User-programmable, Upscale to 23.6mA; Downscale to 3.6mA</p> <p><b>Output Current Limiting:</b> 3.8mA and 21.6mA for input over range; 25mA maximum</p> <p><b>T/C Input Impedance:</b> 40 Mohm nominal</p> <p><b>RTD &amp; Ohm Excitation:</b> 250 microamps, ±10%</p> <p><b>RTD Lead Wire Resistance Maximum:</b> RTD resistance + 2X lead wire resistance should total &lt;4000 ohms; Recommended lead wire resistance for three wire connections, &lt;35 ohm/wire; 10 ohm copper sensor lead wire resistance should total &lt;5 ohm</p> <p><b>Sensor Lead Resistance Effect:</b> 2-wire sensors: Error = 1.0 ohm in reading/ohm of lead resistance; 3-wire sensors: Error = 1.0 ohm in reading/ohm of lead of unbalanced resistance; 4-wire sensors: No effect</p> <p><b>Damping:</b> User set; 0-30 seconds</p> <p><b>Resolution:</b> Input, 20-bit; Output, 16-bit</p> <p><b>Supply Range:</b> 12-28V I.S.; 12-42V normal operation</p>
<p><b>Performance</b></p> <p><b>Input Accuracy:</b> See Table 3</p> <p><b>Analog Output Accuracy:</b> ±0.015% of span</p> <p><b>Overall Accuracy:</b> The overall accuracy of the unit is the combined input and output accuracy. It includes the combined effects of linearity, hysteresis, repeatability and adjustment resolution. It does not include ambient temperature effect. For T/C input only, add the Reference Junction Compensation error</p> <p><b>Reference Junction Compensation:</b> ±0.45°C (±0.81°F)</p> <p><b>Stability:</b> See Table 1</p> <p><b>Isolation:</b> THZ in HPP: 1000Vrms input-to-output continuous; THZ in DIN: 500Vrms input-to-output continuous; THZ in DH and TDZ (all models): 500Vrms input-to-output continuous, and will withstand a 500Vac dielectric strength test for one minute without breakdown</p>	<p><i>Specifications continued on next page</i></p>	

**Table 1. Long-Term Stability Specifications**

Stability (% of maximum span)	Input-to-HART Output (Years)			HART-to-Output Output (Years)		
	1	3	5	1	3	5
THZ-HPP T/C, mV	0.0084	0.0145	0.019	0.0578	0.100	0.129
THZ-HPP RTD, Ohm, Potentiometer	0.013	0.0225	0.029	0.0578	0.100	0.129
THZ-DIN T/C, mV	0.0084	0.0145	0.019	0.08	0.139	0.179
THZ-DIN RTD, Ohm, Potentiometer	0.07	0.121	0.157	0.08	0.139	0.179
TDZ-HP T/C, mV	0.0084	0.0145	0.019	0.08*	0.139*	0.179*
TDZ-HP RTD, Ohm, Potentiometer	0.013	0.0225	0.029	0.08*	0.139*	0.179*
THZ-HP T/C, mV	0.0084	0.0145	0.019	0.0183	0.032	0.041
THZ-HP RTD, Ohm, Potentiometer	0.013	0.0225	0.029	0.0183	0.032	0.041

$$\text{Overall Error} = \sqrt{(\text{Input-to-HART Error} \times \text{Reading}/100)^2 + (\text{HART-to-Output error})^2}$$

\*Consult factory for improved long term drift specifications

**Table 2. Ambient Temperature Effect**

Input Type	Digital Accuracy per 1°C (1.8°F) change	Analog Accuracy per 1°C (1.8°F) change
<b>THZ in DH</b>		
RTD	0.0015°C	0.001% of span (16mA)
T/C	0.0015°C	0.001% of span (16mA)
Millivolt	0.00025mV	0.001% of span (16mA)
Ohm	0.007 ohms	0.001% of span (16mA)
<b>THZ in DIN/HPP/LH/CH6 and TDZ in HP/BH/D-BOX</b>		
RTD	0.003°C	0.004% of span (16mA)
T/C	0.003°C	0.004% of span (16mA)
Millivolt	0.00025mV	0.004% of span (16mA)
Ohm	0.007 ohms	0.004% of span (16mA)

# THZ & TDZ

Smart HART®

Temperature Transmitters

## Specifications (continued)

<p><b>Display (THZ [DH] &amp; TDZ only)</b></p> <p><b>THZ in DH Enclosure:</b> Top Row, 18mm (0.5 in) high black digits on a reflective background; Bottom Row, 10mm (0.4 in) high digits on a reflective background; Two-digit HART address indicator; % of Span shown on a bar graph with upper and lower out-of-range indicators</p> <p><b>TDZ (all models):</b> Top Row, 10mm (0.4 in) high black digits on a reflective background; Bottom Row, 6mm (0.225 in) high digits on a reflective background; two-digit HART address indicator</p> <p><b>Format:</b> Two rows of five alphanumeric characters</p> <p><b>Decimal Points:</b> Automatically adjusting decimal point with a two decimal-place maximum (Analog output display is always two decimal places)</p> <p><b>Range:</b> -99999 to 99999</p> <p><b>Minimum Display Span:</b> 1.00</p>	<p><b>Ambient Temperature and Conditions</b></p> <p><b>Operating &amp; Storage Range:</b> -40°C to +85°C (-40°F to +185°F)</p> <p><b>Relative Humidity:</b> 0-95%, non-condensing</p> <p><b>Ambient Temperature Effect:</b> See Table 2</p> <p><b>Effect on Reference (Cold) Junction Compensation:</b> ±0.005% of input span/°C change of ambient temp.</p> <p><b>RFI/EMI Immunity:</b> THZ in DH/DIN: 30V/m when tested according to SAMA 33.1 abc with 0.5% of span or less error; 10V/m@ 80-1000MHz, 1kHz AM when tested according to IEC 1000-4-3-1995 THZ in HPP/LH/CH6: 10V/m when tested according to SAMA 33.1 abc with 0.5% of span or less error; 10V/m@ 80-1000MHz, 1kHz AM when tested according to IEC 1000-4-3-1995</p>	<p><b>Ambient Temperature and Conditions (Continued)</b></p> <p>TDZ in HP/BH/D-BOX: 20V/m when tested according to SAMA 33.1 abc with 0.5% of span or less error; 10V/m@ 80-1000MHz, 1kHz AM when tested according to IEC 1000-4-3-1995</p> <p><b>Startup Time:</b> Performance within specification 8 seconds after power is applied</p> <p><b>Noise Rejection:</b> Common mode, 100dB@ 50/60Hz; Normal Mode: 70dB typical at 200mVp-p @ 50/60Hz</p> <p><b>Weight</b></p> <p><b>THZ in DIN Housing:</b> 221 g (7.9 oz) <b>THZ in HPP Housing:</b> 101 g (3.6 oz) <b>THZ in LH1 Enclosure:</b> 434 g (15.5 oz) <b>THZ in LH2 Enclosure:</b> 654 g (1 lb., 7.3 oz) <b>THZ in DH Enclosure:</b> 1.75 kg (3 lbs., 14.5 oz) <b>TDZ in HP Housing:</b> 188 g (6.7 oz) <b>TDZ in BH Enclosure:</b> 14.2 kg (3 lbs., 2.5 oz) <b>TDZ in D-BOX:</b> 678 g (1 lb., 7.7 oz)</p>
---	--	--

## Complete Temperature Assemblies

Free yourself from the hassle of looking around for pieces and parts by ordering a complete assembly.

To complement our high-quality transmitters, we carry complete lines of RTDs, thermocouples, thermowells, connection heads and fittings. Get the quality you need and the options you require with the ease of just one ordering number!

For the best accuracy, have your transmitter and sensor calibrated together in our sensor-matching calibration bath.

**See our RTI1 and RTI2 Ready-to-Install Temperature Transmitter Assemblies data sheets for details.**

### Sensor-to-Transmitter Matching

Our sensor matching process starts by immersing the temperature sensor into stabilized temperature baths in our calibration lab. The transmitter captures two points from the sensor and stores them in non-volatile memory. It then uses them to compensate for deviations between a sensor's stated linearization curve and its actual measurements.

Sensor matching provides you with incredible accuracy at an affordable price. Accuracy varies with the sensor, so contact the factory for information on your sensor type.

**Table 3. Input and Accuracy Table**







Input	Type	$\alpha^*$	Ohms	Conformance Range	Minimum Span	Input Accuracy	Maximum Range	Sensor-to-Transmitter Matching
RTD (2-, 3-, 4-Wire)	Platinum	0.003850	100	-200 to 850°C -328 to 1562°F	10°C (18°F)	±0.1°C (±0.18°F)	-240 to 960°C -400 to 1760°F	Up to ±0.014°C (±0.025°F) system accuracy*.  *High-accuracy measurements are achieved by using a 4-wire, 1000 ohm platinum RTD with a span of 100°F (50°F minimum) calibrated in our sensor-matching calibration bath. See page 5 or contact our factory for additional information.
			200					
			300					
			400					
			500					
			1000					
	0.003902	100	-100 to 650°C -148 to 1202°F					
		200						
		400						
		500						
1000								
0.003916	100	-200 to 510°C -328 to 950°F	-240 to 580°C -400 to 1076°F					
Nickel	0.00672	120	-80 to 320°C -112 to 608°F	-100 to 360°C -148 to 680°F				
Copper	0.00427	9.035	-50 to 250°C -58 to 482°F	±0.85°C (±1.53°F)	-65 to 280°C -85 to 536°F			
Ohms	Direct Resistance	n/a	0-4000 ohms	0-4000 ohms	10 ohms	±0.4 ohms	0-4000 ohms	
	Potentiometer	n/a	4000 ohms	0-100%	10%	±0.1%	0-100%	
T/C	J	n/a	n/a	-180 to 760°C -292 to 1400°F	35°C 63°F	±0.25°C (±0.45°F)	-210 to 770°C -346 to 1418°F	
	K	n/a	n/a	-150 to 1370°C -238 to 2498°F	40°C 72°F	±0.3°C (±0.54°F)	-270 to 1390°C -454 to 2534°F	
	E	n/a	n/a	-170 to 1000°C -274 to 1832°F	35°C 63°F	±0.2°C (±0.36°F)	-270 to 1013°C -454 to 1855.4°F	
	T	n/a	n/a	-170 to 400°C -274 to 752°F	35°C 63°F	±0.25°C (±0.45°F)	-270 to 407°C -454 to 764.6°F	
	R	n/a	n/a	0 to 1760°C 32 to 3200°F	50°C 90°F	±0.55°C (±0.99°F)	-50 to 1786°C -58 to 3246.8°F	
	S	n/a	n/a	0 to 1760°C 32 to 3200°F	50°C 90°F	±0.55°C (±0.99°F)	-50 to 1786°C -58 to 3246.8°F	
	B	n/a	n/a	400 to 1820°C 752 to 3308°F	75°C 135°F	±0.75°C (±1.35°F)	200 to 1836°C 392 to 3336.8°F	
	N	n/a	n/a	-130 to 1300°C -202 to 2372°F	45°C 81°F	±0.4°C (±0.72°F)	-270 to 1316°C -454 to 2400.8°F	
	C	n/a	n/a	0 to 2300°C 32 to 4172°F	100°C 180°F	±0.8°C (±1.44°F)	0 to 2338°C 32 to 4240.4°F	
mV	DC	n/a	n/a	-50 to 1000mV	4mV	15 microvolts	-50 to 1000mV	

# THZ & TDZ

Smart HART®

Temperature Transmitters

## Versatile Housing, Enclosure and Mounting Choices

Model	Features	Dimensions
 <p><b>THZ in DH</b> Dual Compartment Field-Mount Enclosure with Display</p>	<ul style="list-style-type: none"> <li>Field-mount dual compartment enclosure isolates and protects the transmitter's electronics from humidity, moisture and corrosive agents brought in through the conduit entries.</li> <li>Extra-large display shows process status in selectable engineering units and HART status/error messages. A bar graph shows the output value in percent of span.</li> <li>Modular transmitter electronics can be easily removed without disturbing the enclosure or sensor assembly.</li> </ul>	Page 12
 <p><b>THZ in LH</b> Connection Head Field-Mount Enclosure</p>	<ul style="list-style-type: none"> <li>Compact, lightweight connection head mounts right on the thermowell/sensor assembly, or in a convenient location remote from the sensor.</li> <li>Encapsulated electronics resist the harmful affects of moisture and humidity that enter though the conduit connections.</li> <li>Explosion-proof and very affordable general location (NEMA 4X, IP66) versions available.</li> </ul>	Page 13
 <p><b>THZ in HPP</b> Encapsulated Housing</p>	<ul style="list-style-type: none"> <li>Small size and protected, encapsulated electronics make this model ideal for integrating into industrial machinery, machine tools, facility monitoring systems and similar production and process equipment.</li> <li>For retrofit applications, standard diameter and mounting hole dimensions allow easy integration into installed thermowell and remote-mounted connection heads.</li> </ul>	Page 14
 <p><b>THZ in DIN</b> Rail Mount Housing</p>	<ul style="list-style-type: none"> <li>Only 25mm (1-inch) wide, this compact model is perfect for mounting in a control room, high-density instrument cabinet or field-mounted enclosure.</li> <li>Universal mounting bracket easily snaps on and off of G-type and top hat DIN-rails, and standard relay tracks.</li> <li>Metal, temperature-compensating terminal blocks provide exceptionally stable measurements even in fluctuating ambient temperature conditions.</li> </ul>	Page 14
 <p><b>TDZ in HP</b> Hockey-Puck Housing with Display</p>	<ul style="list-style-type: none"> <li>Mounts on a surface, on G-type or top hat rails and on relay track when on site display is needed in a control room, cabinet or enclosure.</li> <li>Replacement transmitter installs in a Moore Industries BH or D-BOX enclosure and in other common field-mount instrument enclosures.</li> </ul>	Page 15
 <p><b>TDZ in BH</b> Field-Mount Enclosure (shown)</p> <p><b>TDZ in D-BOX</b> Field-Mount Enclosure</p>	<ul style="list-style-type: none"> <li>Economical choice when reliable field protection and on site indication are required.</li> <li>Modular transmitter electronics can be easily removed without disturbing the enclosure or sensor assembly.</li> <li>Explosion-proof and economical general location (NEMA 4X, IP66) models available.</li> </ul>	<p><b>BH</b> Page 15</p> <p><b>D-BOX</b> Page 16</p>

## Ordering Information

Unit	Input	Output	Power	Options	Housing
<b>THZ</b> Smart HART Temperature Transmitter With and Without Display	<b>PRG</b> Program-mable with standard HART communicator, HART-based control system, or Intelligent PC configuration Software for:  <b>RTD</b> 2-, 3-, 4-Wire Platinum, Copper, Nickel  Thermocouple (J, K, E, T, R, S, B, N, C)  0-4000 ohms  -50-1000mV  (see Table 3 for additional information)	<b>4-20MA</b> Scaleable to narrower ranges	<b>12-42DC</b> <b>12-30DC</b> I.S. & N.I. applications	<b>-ISF</b> FM approved Intrinsically Safe (I.S.) & Non-Incendive (N.I.) <b>-FMEDA</b> Unit comes with Failure Modes, Effects and Diagnostic Analysis (FMEDA) data for evaluating the instrument for suitability of use in a safety-related application	<b>DH Dual-Compartment Enclosure:</b> <b>DH2NG</b> Explosion-Proof Dual-compartment enclosure with two, 1/2-inch NPT entry ports and a glass cover <b>DH2TG</b> Explosion-Proof Dual-compartment enclosure with two, 3/4-inch NPT entry ports and a glass cover <b>DH2MG</b> Explosion-Proof Dual-compartment enclosure with two, M20 x 1.5 entry ports and a glass cover <b>DH</b> Replacement transmitter module with out enclosure  P suffix indicates enclosure is equipped with 2" pipe-mount hardware kit (DH2NGP)
				<b>-ISC*</b> CSA approved I.S. & N.I. <b>-ISE*</b> LCIE/ATEX approved I.S. <b>-ISF*</b> FM approved I.S. & N.I. <b>-FMEDA</b> Unit comes with Failure Modes, Effects and Diagnostic Analysis (FMEDA) data for evaluating the instrument for suitability of use in a safety-related application  *HPP/LH2	
<b>TDZ</b> Smart HART Temperature Transmitter with Display	<b>PRG</b> (see description above for details)	<b>4-20MA</b> Scaleable to narrower ranges	<b>12-42DC</b> <b>12-30DC</b> I.S. & N.I. applications	<b>-ISC</b> CSA approved I.S. & N.I. <b>-ISE</b> LCIE/ATEX approved I.S. <b>-ISF</b> FM approved I.S. & N.I.	<b>HP Hockey-Puck, BH and D-BOX Enclosures:</b> <b>HP</b> Hockey puck housing and spring clips <b>DN</b> Snap-in mounting for HP case on TS-32 DIN-rail <b>FL</b> Mounting flanges on HP for relay track or screw mounting <b>FLD</b> Mounting flanges on HP for 3½" relay track mounting <b>BH2NG</b> Explosion-Proof enclosure with two 1/2-inch NPT entry ports and a glass cover <b>BH2TG</b> Explosion-Proof enclosure with two 3/4-inch NPT entry ports and a glass cover <b>BH2MG</b> Explosion-Proof enclosure with two M20 x 1.5 NPT entry ports and a glass cover <b>BH3NG</b> Explosion-Proof enclosure with three 1/2-inch NPT entry ports <b>BH3TG</b> Explosion-Proof enclosure with two 3/4-inch side-entry NPT ports, one 1/2" bottom port, and a glass cover <b>BH3MG</b> Explosion-Proof enclosure with two, M20 x 1.5 side-entry ports, one 1/2" bottom-entry port, and a glass cover <b>SB2NG</b> 2-Hub, Explosion-Proof enclosure with two, ½-inch NPT entry ports and a glass cover <b>SB2MG</b> 2-Hub, Explosion-Proof enclosure with two, M20 x 1.5 entry ports and a glass cover) <b>D2LC</b> 2-Hub, low base, clear cover, IP66/NEMA 4X enclosure  A suffix indicates SAA/TestSafe (Ex d) Flame-Proof approvals (i.e. BH2MGA) E suffix with BH denotes ATEX Flame-Proof enclosures; 2" pipe-mount kit is included (BH2MGE) P suffix indicates enclosure is equipped with 2" pipe-mount hardware kit (BH2NGP)

### Additional Parts

Each order comes with one copy of our Configuration Software (Windows® compatible). The HART RS-232 Modem and the HART Communicator must be purchased separately:

**P/N 235-829-02**—PC-Programming Kit includes one copy of our Intelligent PC Configuration Software and one HART-to-RS232 Cable with HART modem.

**P/N 750-75E05-01**—Interface Solution PC Configuration Software on CD (One copy comes free with each order).

**P/N 803-048-26**—HART-to-RS232 Smart Interface Cable with HART Modem.

**To order, specify:** Unit / Input / Output / Power / Option [Housing]  
**Model Number Example:** THZ / PRG / 4-20MA / 12-30DC / -ISF [DH2NGP]  
 TDZ / PRG / 4-20MA / 12-42DC [BH2NGE]

# THZ & TDZ

Smart HART®

Temperature Transmitters

Figure 7. Dimensions for the THZ in DH dual compartment enclosure

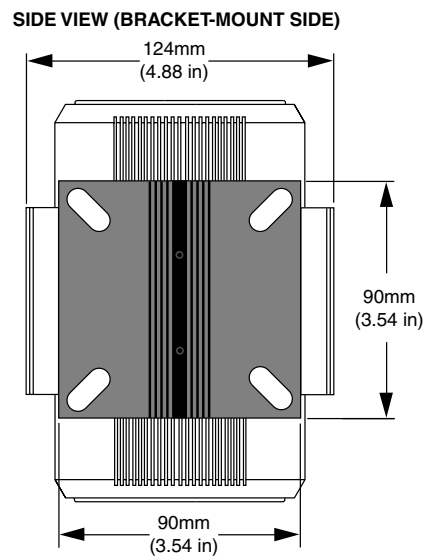
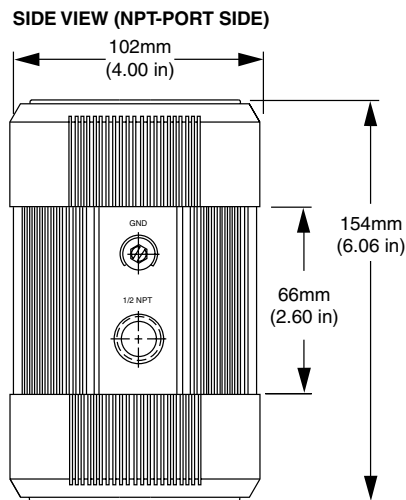
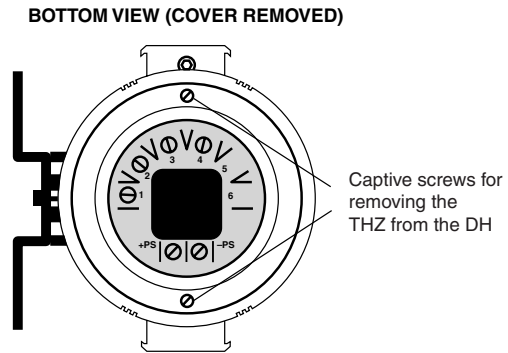
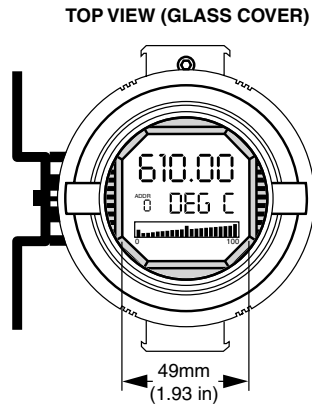
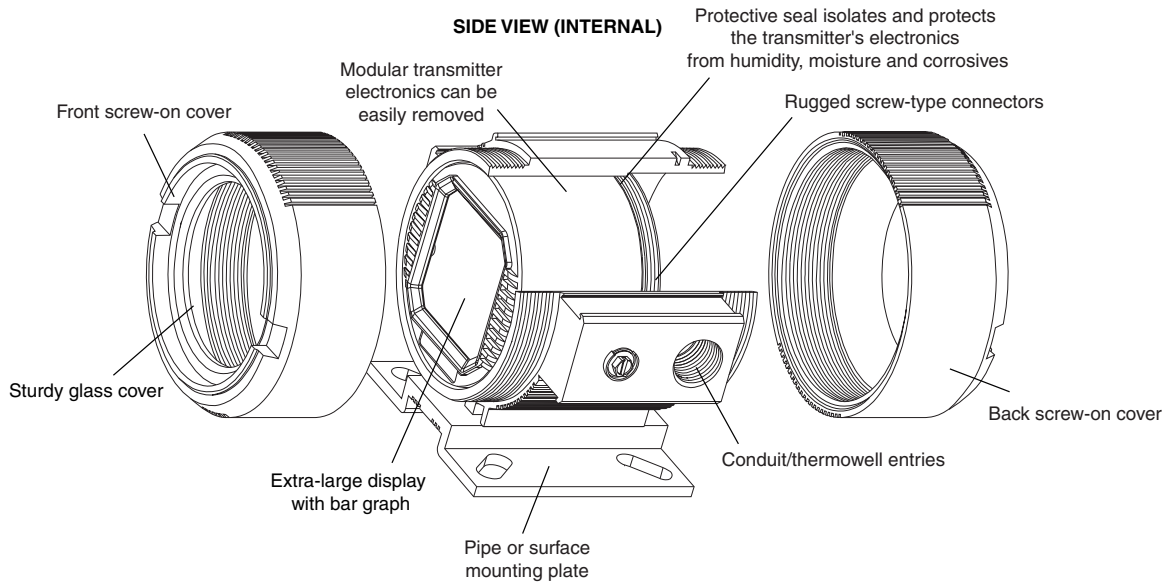
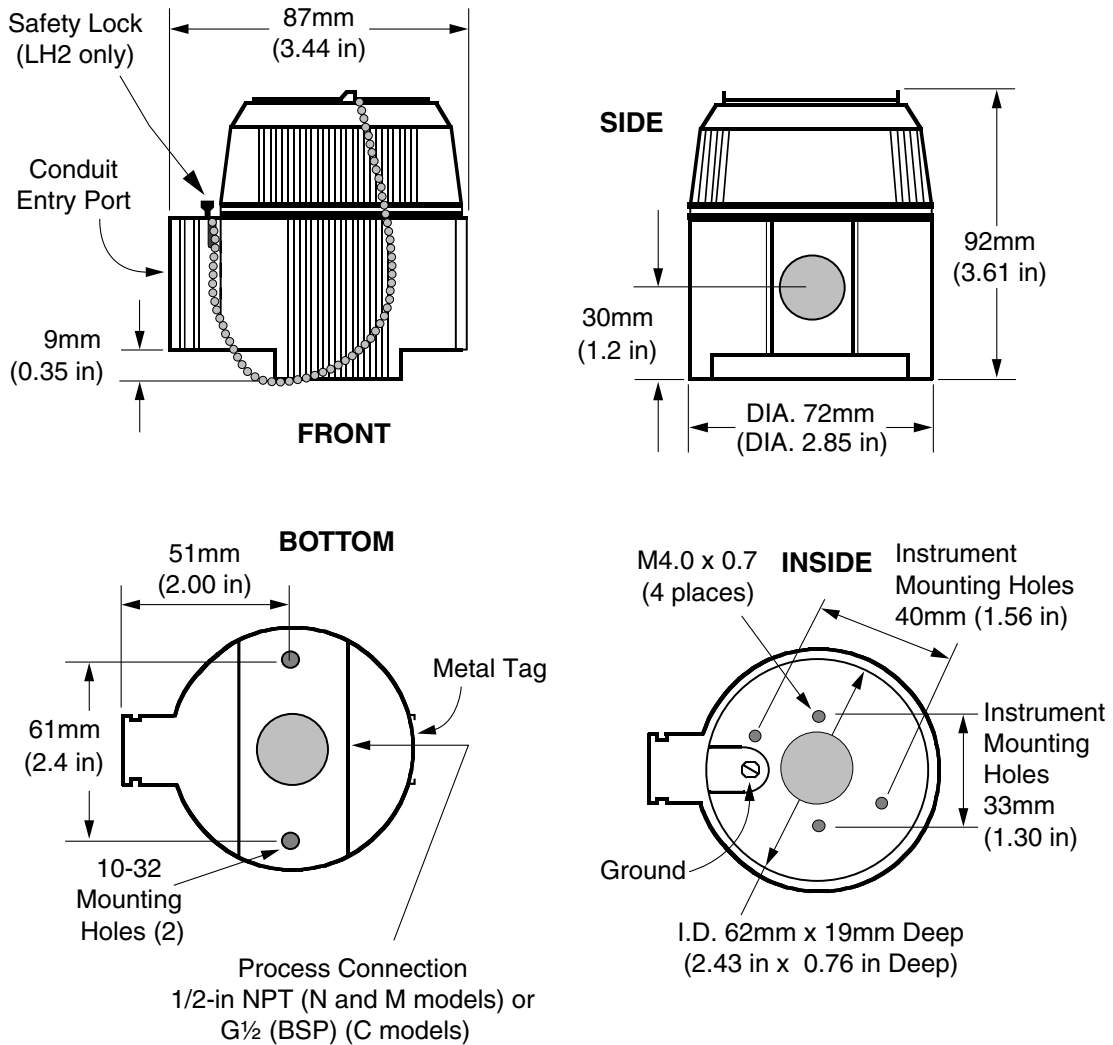
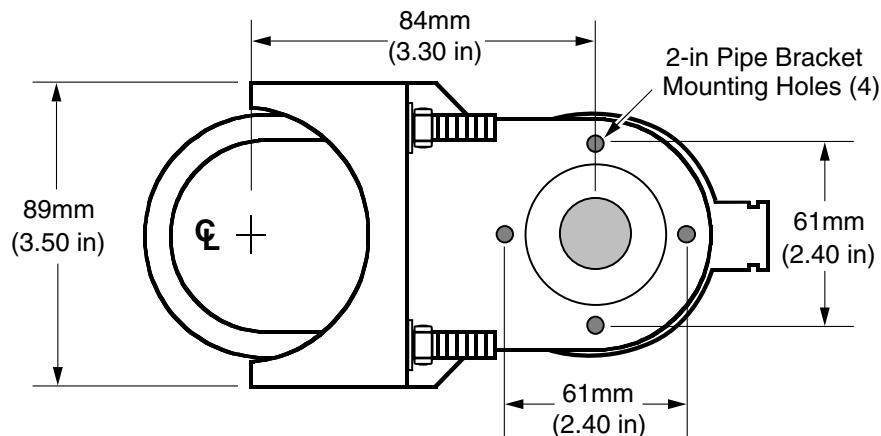

Figure 8. Dimensions for the THZ in the LH connection head



### 2-INCH PIPE MOUNTING HARDWARE



# THZ & TDZ

Smart HART®

Temperature Transmitters

Figure 9. Dimensions for the THZ in the HPP hockey-puck housing

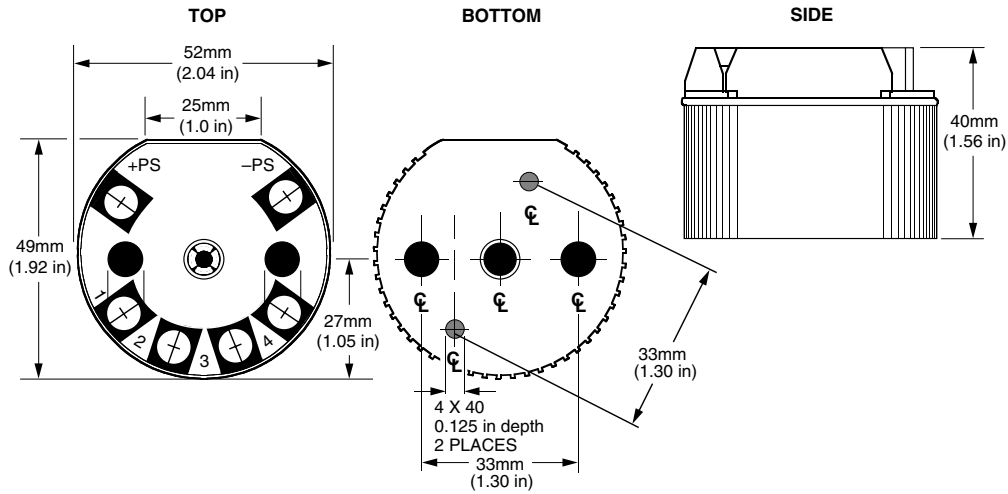

Figure 10. Dimensions of the THZ in the DIN rail-mount housing

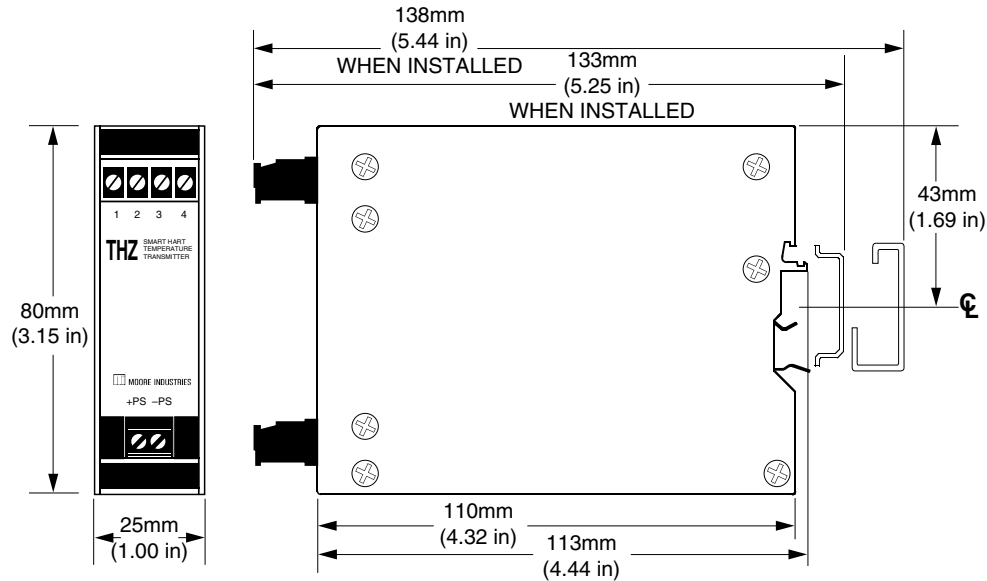

Figure 11. Sensor/input connections for the THZ and TDZ (While terminal placement may differ from unit to unit, all models use identical numeric designations.)

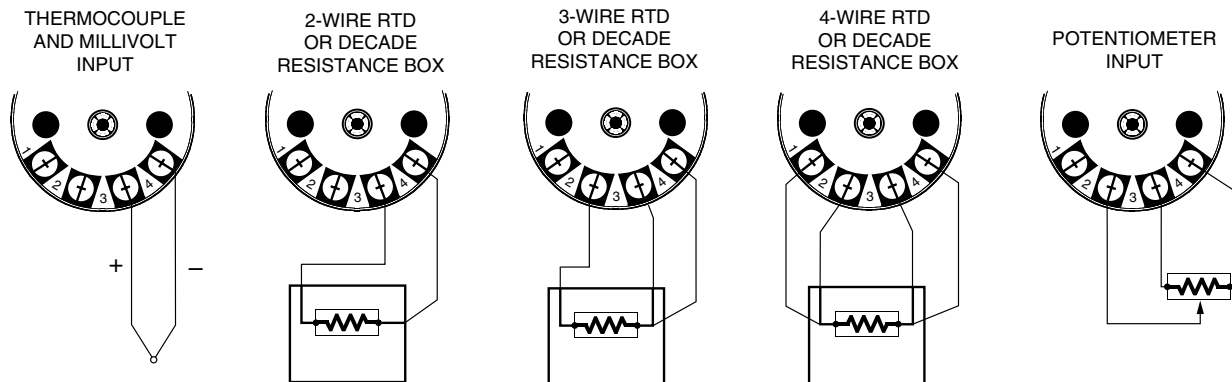

Figure 12. Dimensions for TDZ in HP hockey-puck housing

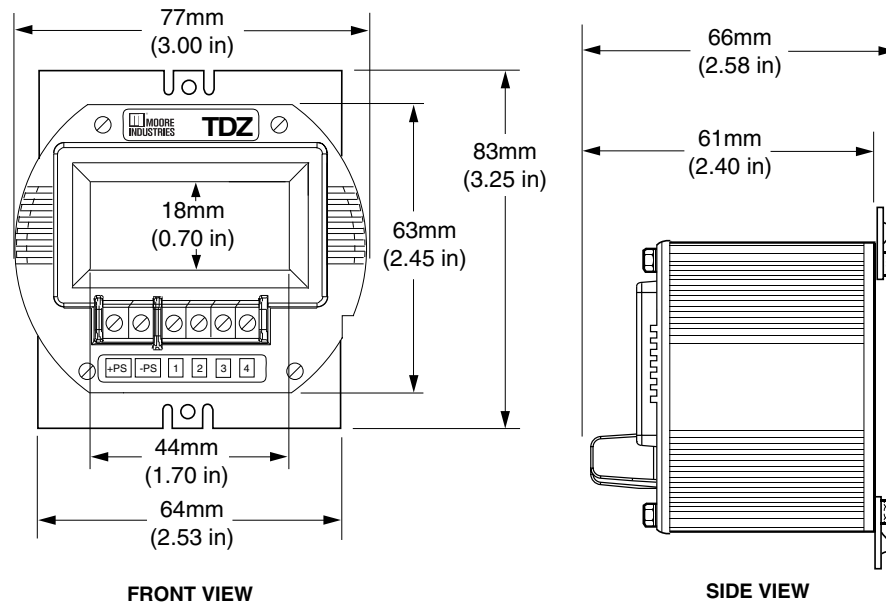
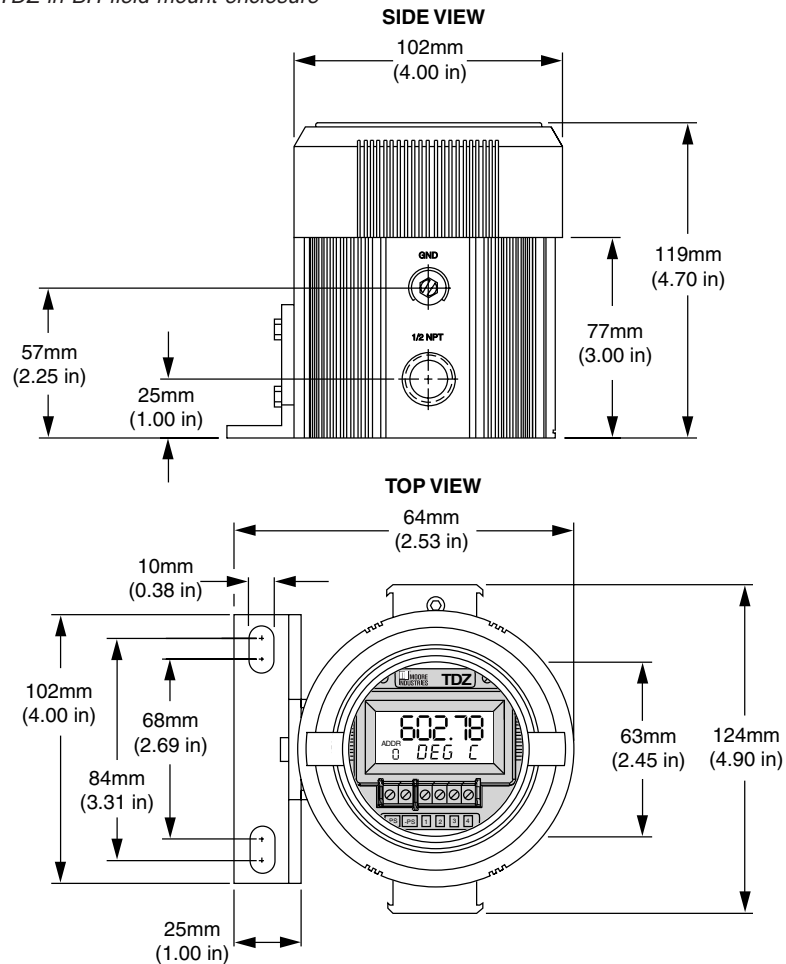

Figure 13. Dimensions for the TDZ in BH field-mount enclosure



# THZ & TDZ

Smart HART®

Temperature Transmitters

Figure 14. Dimensions for TDZ in D-BOX field-mount enclosure

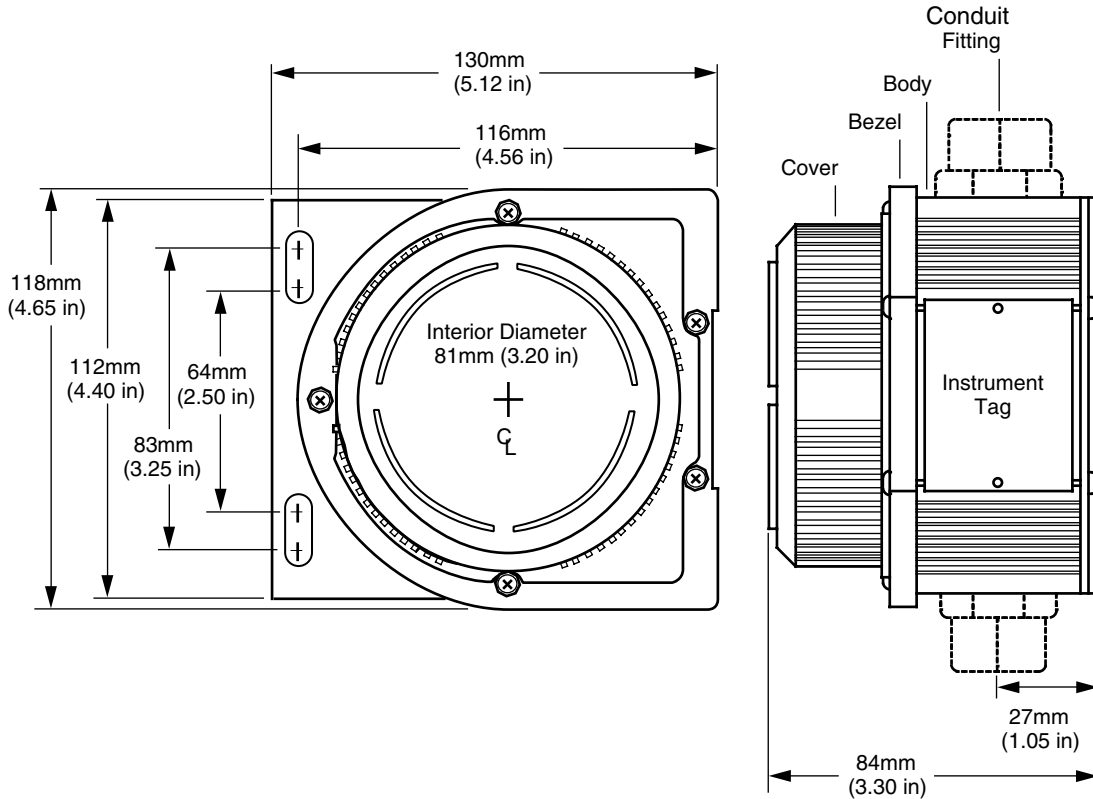

## Certifications



**Factory Mutual Approvals - FM Global Explosion-Proof & Dust-Ignition Proof**  
[TDZ-HP/BH and SB Housings, THZ-DH, THZ-HPP/LH2] –

Class I, Division 1, Groups A\*, B, C, D  
Class II & III, Division 1, Groups E, F, G

**Environmental Protection:** NEMA 4X & IP66

**Temperature Code:**

T6@60°C Max. Operating Ambient Temperature

**Intrinsically Safe** [TDZ-HP, THZ-DH, THZ-HPP] –  
Class I/II/III, Division 1, Groups A-G

**Non-Incendive**

[TDZ-HP, THZ-DIN, THZ-DH, THZ-HPP] –

Class I, Division 2, Groups A, B, C, D  
Suitable for: Class II & III, Division 2, Groups F, G

**Temperature Code:**

TDZ-HP/THZ-DH/THZ-DIN: T4A@40°C & T4@60°C  
THZ-HPP: T6@60°C Max. Op. Temp.

## SAA TestSafe (Australian) Approvals:

Flame-Proof [THZ-HPP in LH2 and TDZ-HP in BH Housing]  
Ex d IIC T6, IP66

\*BH & LH2 only: For 'Group A' applications, seal all conduits within 18".



**Canadian Standards Association (CSA Int'l)**

**Intrinsically Safe** [TDZ-HP, THZ-HPP] –

Class I, Division 1, Groups A-D

**Non-Incendive** [TDZ-HP, THZ-DIN, THZ-HPP] –

Class I, Division 2, Groups A, B, C, D

**Temperature Code:**

TDZ-HP/THZ-DIN: T4A@40°C & T4@60°C

THZ-HPP: T6@60°C Max. Op. Temp.



**CENELEC/ATEX 94/9/EC Directive**

**ISseP Flame-Proof** –

[TDZ-HP in BH] –

⊕ II 2GD EEx d IIC, T6@60°C, IP66

**ISSeP** [THZ-HPP in LH2] –

⊕ II 2GD EEx d IIC, T6@60°C, IP66

**Intrinsically Safe -**

**LCIE** [TDZ-HP, THZ-HPP] –

⊕ II 2G EEx ib IIC

**Temperature Code:**

T4@60°C (TDZ-HP), T6@60°C (THZ-HPP)



**CE Conformant**–EMC Directive 89/336/EEC  
EN 61326



United States • info@miinet.com  
Tel: (818) 894-7111 • FAX: (818) 891-2816  
Australia • sales@mooreind.com.au  
Tel: (02) 8536-7200 • FAX: (02) 9525-7296

Belgium • info@mooreind.be  
Tel: 03/448.10.18 • FAX: 03/440.17.97  
The Netherlands • sales@mooreind.nl  
Tel: (0)344-617971 • FAX: (0)344-615920

China • sales@mooreind.sh.cn  
Tel: 86-21-62481120 • FAX: 86-21-62490635  
United Kingdom • sales@mooreind.com  
Tel: 01293 514488 • FAX: 01293 536852