

Description

The universal SPA Site-Programmable Alarms provide on/off control, warn of trouble, or provide emergency shutdown. They accept a direct input from transmitters, temperature sensors, and a wide array of other monitoring and control instruments:

- **Current and Voltage Signals**
(4-20mA, 1-5V, 0-250Vac, 0-5A, etc.)
- **23 RTD Types**
(2-, 3-, and 4-wire; Pt, Cu and Ni; 10 to 1000 ohms)
- **8 Thermocouple Types**
(J, K, E, T, R, S, B, and N)
- **Resistance and Potentiometer Devices**
(0 to 4000 ohms)
- **Direct Millivolt Sources**
(-10 to 120mV)

They provide two or four alarm relay outputs when a monitored process variable falls outside of user-set high and/or low limits. Connect the 4-wire (line-powered) SPA to a warning light, annunciator, bell, or shutdown system, and your process is protected by a simple, highly reliable, independent warning and/or shutdown strategy.

Table of Contents	Page
Family Overview of SPA Site-Programmable Functions and Special Features	2-3
mA and Vdc Input Models (HLPRG)	4-5
Vac and Amp Input Models (ACPRG and ACIPRG)	6-7
RTD, Thermocouple, Ohm (Resistance/Potentiometer) and mV Input Models (TPRG)	8-11
Housing and Installation Dimensions (All Models)	12-13
Terminal Designations and Hookups (All Models)	14-15
Typical SPA Universal Alarm Solutions	16



The SPA Site-Programmable Alarm features a metal, RFI resistant housing that snaps onto standard rails.

Features

- **Universal plant standard.** There's no need to stock dozens of different fixed range alarm trips.
- **Site-programmable with on-board controls.** Your fingers are the only tools you need to get our SPA up and running fast. All operating parameters configure using on-board controls.
- **Real-time process readout.** A front panel indicator provides menu prompts during configuration, and displays the process variable in user-selectable engineering units.
- **Alarm trip and transmitter combination.** The analog output option reduces costs and installation time when both transmitter and alarm functions are needed at the same location (see Page 3).

Certifications

 **Canadian Standards Association (CSA) General (Ordinary) Location – NRTL/C**

 **Factory Mutual Research - FM Global Non-Incendive/Hazardous Locations: Class I, Division 2, Groups A, B, C, D (-HS option required)**
Suitable For: Class II, Division 2; Class III, Division 1, 2

 **CE Conformant – EMC Directive 89/336/EEC EN 61326**

SPA

Site-Programmable Current/Voltage and RTD/Thermocouple Limit Alarm Trips

On-Site Programming

Input type, range, trip points, and other frequently changed operating parameters configure quickly and easily from the front panel keypad. Simple prompts on the SPA's LCD guide you through a "plain-English" selection menu. Available programmable functions include*:

- Input type and range
- Zero and full scale
- Alarm trip points, high or low alarm, deadband, time delay, latching or non-latching
- Engineering unit readout (V, mA, %, °C, °F, psig, mV, ohms, or optional custom engineering units)
- Position of LCD decimal point for custom engineering unit representation
- Upscale or downscale drive on sensor failure
- T/C reference junction compensation (on/off)
- Standard and custom linearization curves
- Differential or averaging of RTD inputs
- Current source or sink, or voltage output
- Security password protection

* Some of the programmable functions listed are not applicable to, or available on, all models.

Figure 1. Available models deliver versatile input/output choices.

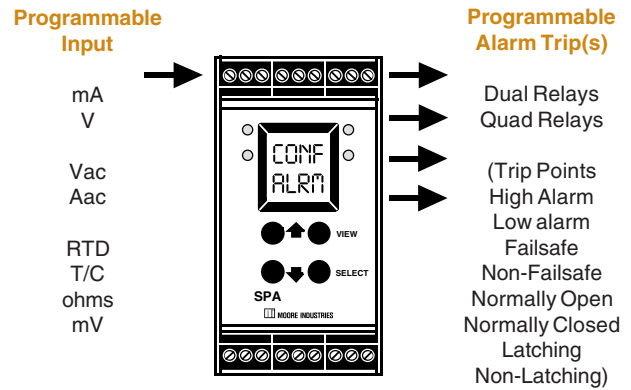

Quick Ranging Calibration

The SPA features our revolutionary "Quick Ranging Calibration" method. Using the push buttons (instead of potentiometers which can drift) and the integral display, precise zero and span settings can be made in seconds. All you have to do is scroll to the zero or span value you want and a push of a button locks the value into the SPA's memory.

Figure 2. Menu prompts on the front panel LCD guide you through setup and viewing options.

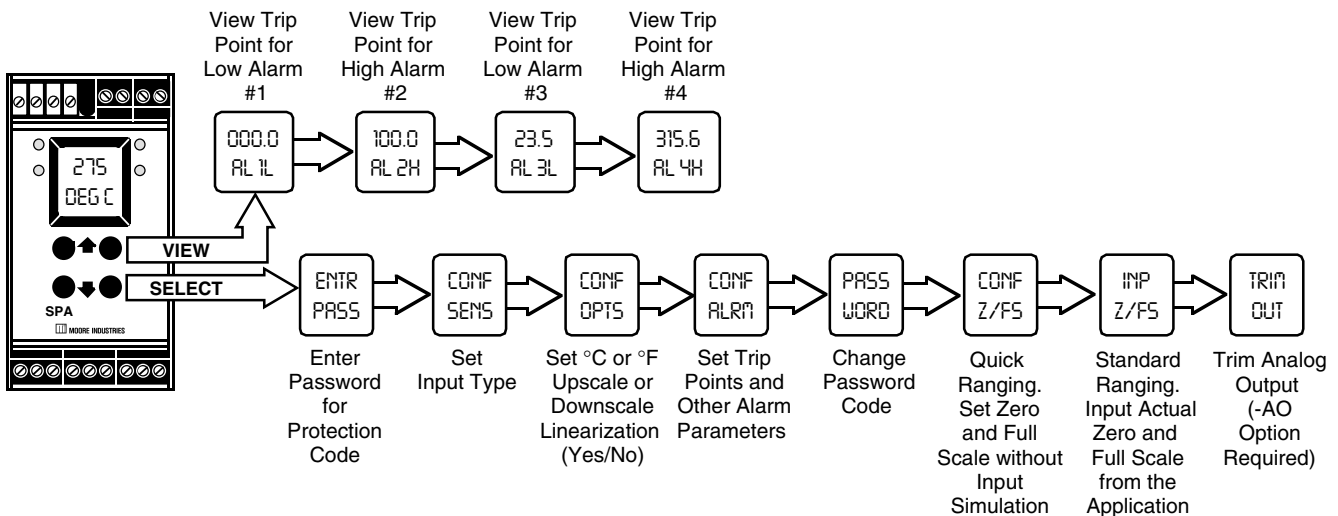

Combination Alarm and Isolated Transmitter

When ordered with the -AO (or -AOZ) Analog Output option, the SPA provides an analog retransmission of the input signal that can be sent to remote monitoring/control devices like a DCS, PLC, PC, indicator, or data recorder (Figure 3). From the front-panel keypad, you can adjust zero and span, and whether you want the output to be linear or non-linear with the input.

1000Vrms isolation between the case, input, output(s), and power supply stops the effects of harmful ground loop noise.

Continuous Self-Diagnostics

Incorporating advanced self-diagnostics, the SPA checks its own operation and configuration upon start up, and then continuously monitors its status during operation. If it senses that it is not operating properly, it displays a message on its LCD indicating what condition has occurred.

Custom 22-Point Linearization Curves

Current and voltage SPA models can be programmed with up to 22 custom linearization points from the front panel keypad (Figure 4). The ability to plot a custom linearization curve is beneficial when non-linear input signals must be converted to linear output representations. Typical applications include monitoring a non-linear transducer, the level of odd-shaped tanks, and flow meter linearization.

Security Password Protection

A security password system can be used to protect setup data from unauthorized or inadvertent changes. Once the password protection feature is activated, the SPA's operating parameters cannot be altered unless the correct password has been entered on the keypad.

Worldwide Power "Auto-Sensing"

Without adjustment, the SPA accepts every AC and DC power input (22-300Vdc and 90-260Vac). Just apply power and you're up and running.

NOTE: Units with CE approval must be ordered with fixed power supplies (24DC, 117AC, or 230AC). See the Ordering Information tables for details.

Figure 3. When equipped with the Analog Output (-AO) option, the SPA is a combination alarm trip and transmitter.

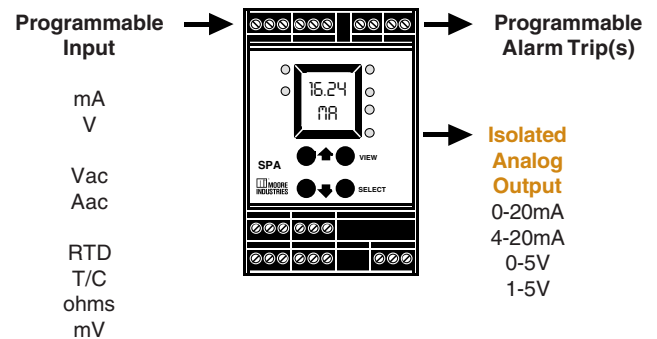
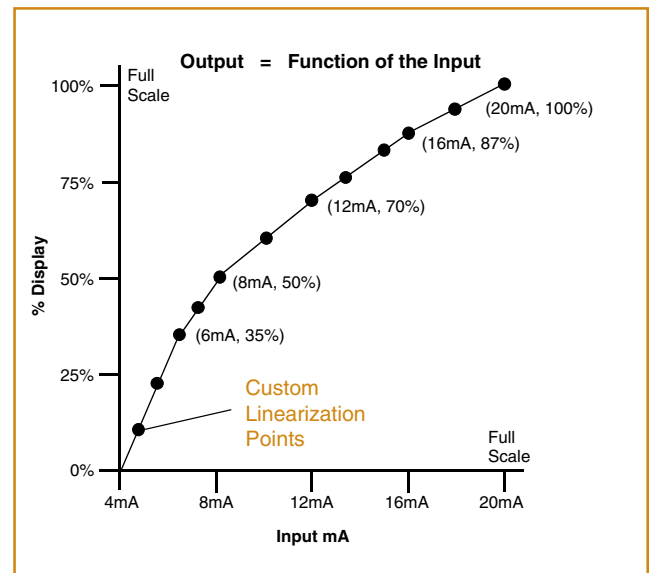

Figure 4. Up to 22 custom linearization points can be selected and saved in the SPA's memory to compensate for non-linear input signals.



SPA

Site-Programmable Current/Voltage and RTD/Thermocouple Limit Alarm Trips

mA and Vdc Input Model

This SPA connects in series on a process loop, and accepts a direct process signal from a transmitter, transducer, or other similar instrument. It provides two or four relay outputs if user-selectable high and/or low limits are exceeded.

Analog Output Option

With the -AO option the SPA provides an isolated and scaleable analog output. The analog signal is proportional to the monitored process variable, and is ideal for sending to a DCS, PLC, indicator, recorder, or similar readout device.

Custom Display Parameters

The decimal position, and zero and full scale display settings, can be selected from the keypad. This feature is useful for representing a specific engineering unit numeric value, as opposed to a direct percentage of the current or voltage input.

Custom, 22-Point Linearization Curves

The mA and Vdc input SPA can be programmed with up to 22 custom linearization points from the front panel keypad (see Page 3 for details).

Figure 5. Current (mA) and Voltage (Vdc) inputs.

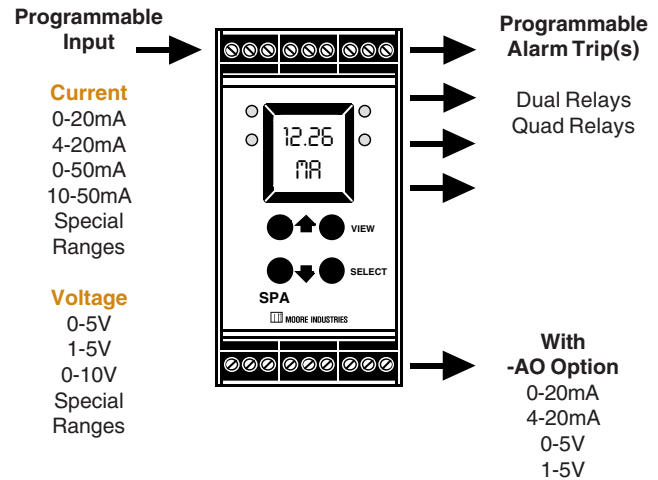

Powers a 2-Wire Transmitter

This SPA model comes standard with 2-wire transmitter excitation (Figure 6). If there is no power supply available to drive the input transmitter, the SPA provides 24Vdc to power the loop. This saves the cost of specifying and installing an additional instrument power supply.

Ordering Information

Unit	Input	Output	Power	Options	Housing
SPA Site-Programmable Alarm Trip	HLPRG Programs to accept: Current: Any range between 0-50mA (0-20mA, 4-20mA, 0-50mA, 10-50mA, etc.) Voltage: Any range between 0-10V (0-5V, 1-5V, 0-10V, etc.) NOTE: Recommended minimum span is 4mA for current inputs and 1V for voltage inputs. Narrower spans are possible, but may result in degradation of the stated output accuracy specification.	2PRG Dual Relays 4PRG Quad Relays (Single Relay and Triple Relay versions are also available. Consult the factory for details) Each relay individually configures for: High or Low Trip Normally Open or Normally Closed Failsafe or Non-Failsafe Latching or Non-Latching (Relays are single-pole/double-throw (SPDT), 1 form C, rated 5A @ 250Vac, 50/60Hz or 24Vdc, non-inductive)	U Universal, 4-wire (line) power; accepts any power input range between 22-300Vdc or 90-260Vac For CE approved units, specify one of the following: 24DC ±10% 117AC ±10% 230AC ±10%	-AO Analog output scaleable for any range between 0-20mA (4mA span, minimum) into 1200 ohms or 0-5V (1V span, minimum) into 10 kohms -DPDT Double-pole/double-throw relays, 2 form C relays, rated 5A @ 250Vac, 50/60Hz, non-inductive (2PRG output type only) -FMEDA Unit comes with Failure Modes, Effects and Diagnostic Analysis (FMEDA) data for evaluating the instrument for suitability of use in a safety-related application -HS Hermetically sealed relays, rated 0.5A @ 117Vac and 2A @ 28Vdc	DIN Universal DIN-style housing mounts on 32mm (EN50035) G-type and 35mm (EN50022) Top Hat DIN-rails

When ordering, specify: Unit / Input / Output / Power / Options [Housing]

Model number example: SPA / HLPRG / 4PRG / U / -AO [DIN]

Specifications (mA and Vdc Input Model)

<p>Performance Repeatability: Trip point repeats within $\pm 0.05\%$ of input span Display Accuracy: ± 1 digit; When scaling the display (in Custom Mode), high input-to-display span ratios decrease display accuracy Input Accuracy: Current input, ± 5microamps; Voltage inputs, ± 1mV Stability: $\pm 0.1\%$ of calibrated span, maximum, over 6 months Deadband: 11.5V or 57.5mA, maximum in Linear Mode; equivalent of maximum input range in user-set engineering units in Custom Mode Response Time: 600 milliseconds (Defined as time from step change on input to alarm state change when alarm is set to trip at mid-point) Alarm Trip Delay: Programmable from 0-60 seconds Line Voltage Effect: $\pm 0.005\%$ of span for a 1% change in line voltage (AC or DC) Isolation: 1000Vrms between case, input, output (units with -AO option) and power terminals (NOTE: High voltage effect of $\pm 0.0004\%$ of output span/V possible with prolonged exposure to ac voltage above 200Vac) Power Consumption: 2-4W, nominal; 6W, maximum</p>	<p>Performance (continued) Input Impedance: 1 Mohm for voltage inputs; 20 ohms nominal for current inputs Input Over-Range Protection: 18Vdc for voltage inputs; 180% of maximum input span</p> <p>Performance with Analog Output (-AO Option) WITH ANALOG OUTPUT Output Accuracy: $\pm 0.03\%$ of output span (includes the combined effects of linearity, hysteresis, repeatability, and adjustment resolution) Response Time: 250 msec maximum time for output to go from 10% to 90% for step change on input Ripple (up to 120Hz): Current output, 10mV peak-to-peak maximum when measured across a 250 ohm resistor; Voltage output, 15mV peak-to-peak maximum Output Limiting: 117% of span maximum, 115% of span typical Load Effect: $\pm 0.01\%$ of span from 0 to maximum load resistance on current output</p> <p>Ambient Conditions Operating Range: -25°C to $+65^{\circ}\text{C}$ (-13°F to $+149^{\circ}\text{F}$) Storage Range: -40°C to $+80^{\circ}\text{C}$ (-40°F to $+176^{\circ}\text{F}$) Ambient Temperature Effect: $\pm 0.005\%$ of output span per $^{\circ}\text{C}$ maximum; ± 15ppm of input signal</p>	<p>Ambient Conditions (continued) Relative Humidity: 0-95% non-condensing RFI/EMI Protection: 30V/m- ABC $\leq 0.5\%$ error in reading when tested according to SAMA standard PMC 33.1 Common Mode Rejection: 100dB @ 60Hz Normal Mode Rejection: 40dB @ 60Hz (measured with current input)</p> <p>Adjustments Front panel push buttons control settings for zero, span, alarm trip points, high/low alarms, etc.; Easy access internal settings select current (source or sink) or voltage output, and failsafe or non-failsafe alarm functions; Internal jumper and menu password protect parameter settings</p> <p>Indicators LCD: 2x4 character, backlit, alphanumeric readout accurate to the nearest digit. Range: -9999 to 9999; Decimal point can be user-set when in Custom Mode LED's: Dual-color TRIP light (one for each relay) shows green for non-alarm, red for alarm; READY light indicates normal operation, extinguishes in the event of any internal failure; INPUT light is always green</p> <p>Weight 456 to 513 g (16.1 to 18.1 oz)</p>
--	---	--

Figure 6. Transmitter Excitation powers the 2-wire transmitter.

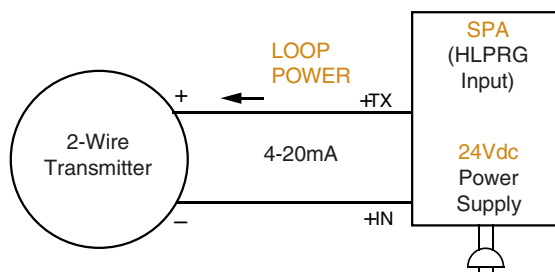

SPA

Site-Programmable Current/Voltage and RTD/Thermocouple Limit Alarm Trips

Vac and Amp Input Model

This SPA connects on a process loop, and accepts direct Vac or Amp signals, such as those produced by a current (CT) or potential (PT) transformer. It provides one or two relay outputs if user-selectable high and/or low limits are exceeded.

Analog Output Option

With the -AO option the SPA provides an isolated and scaleable analog output. The analog signal is proportional to the monitored process variable, and is ideal for sending to a DCS, PLC, indicator, recorder, or similar readout device.

Custom Display Parameters

The decimal position, and zero and full scale display settings, can be selected from the keypad. This feature is useful for representing a specific engineering unit numeric value, as opposed to a direct percentage of the current or voltage input.

Figure 7. Vac and Amp inputs.

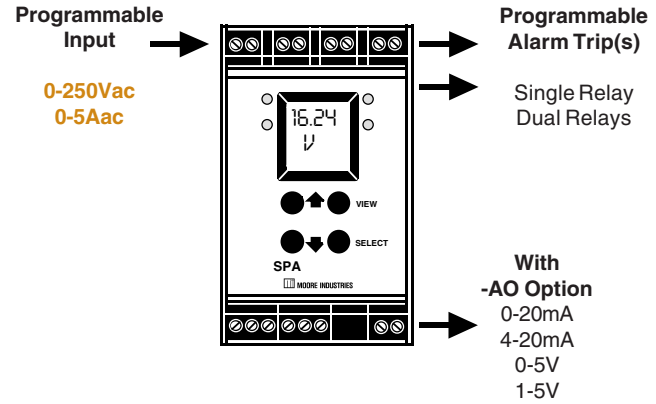

Custom, 22-Point Linearization Curves

The current and voltage SPA can be programmed with up to 22 custom linearization points from the front panel keypad (see Page 3 for details).

Ordering Information

Unit	Input	Output	Power	Options	Housing
SPA Site-Programmable Alarm Trip	<p>ACVPRG Programs to accept AC voltage signals from 0-250Vac</p> <p>ACIPRG Programs to accept AC current signals from 0-5Aac</p> <p>NOTE: Recommended minimum span is 24Vac for voltage inputs and 1Aac for current inputs. Narrower spans are possible, but may result in degradation of the stated output accuracy specification.</p>	<p>1PRG Single Relay (with -DPDT only)</p> <p>2PRG Dual Relays</p> <p>Each relay individually configures for: High or Low Trip Normally Open or Normally Closed Failsafe or Non-Failsafe Latching or Non-Latching</p> <p>(Relays are single-pole/double-throw (SPDT), form 1C, rated 5A @ 250Vac, 50/60Hz or 24Vdc, non-inductive)</p>	<p>U Universal, 4-wire (line) power; accepts any power input range between 22-300Vdc or 90-260Vac</p> <p>For CE approved units, specify: 24DC ±10%</p>	<p>-AO Analog output scaleable for any range between 0-20mA (4mA span, minimum) into 1200 ohms or 0-5V (1V span, minimum) into 10 kohms</p> <p>-DPDT Double-pole/double-throw relays, form 2C relays, rated 5A @ 250Vac, 50/60Hz, non-inductive (1PRG output type only)</p> <p>-FMEDA Unit comes with Failure Modes, Effects and Diagnostic Analysis (FMEDA) data for evaluating the instrument for suitability of use in a safety-related application</p> <p>-SW Provides a relay input that determines if the motor being monitored is running (Alarm 1 is active), or if motor is not running (Alarm 1 is inactive)</p>	<p>DIN Universal DIN-style housing mounts on 32mm (EN50035) G-type and 35mm (EN50022) Top Hat DIN-rails</p>

When ordering, specify: Unit / Input / Output / Power / Options [Housing]

Model number example: SPA / ACVPRG / 2PRG / U / -AO [DIN]

Specifications (Vac and Amp Input Model)

<p>Performance</p> <p>Repeatability: Trip point repeats within $\pm 0.1\%$ of input span</p> <p>Display Accuracy: ± 1 digit; When scaling the display (in Custom Mode), high input-to-display span ratios decrease display accuracy</p> <p>Input Accuracy: Current input, $\pm 5.0\text{mAac}$; Voltage input, $\pm 0.25\text{Vac}$ ($\pm 0.1\%$ of maximum span)</p> <p>Stability: $\pm 0.1\%$ of calibrated span, maximum, over 6 months</p> <p>Deadband: 250V or 7.5A, maximum in Linear Mode; equivalent of maximum input range in user-set engineering units in Custom Mode</p> <p>Response Time: 600 milliseconds (defined as time from step change on input to alarm state change when alarm is set to trip mid-point)</p> <p>Alarm Trip Delay: Programmable from 0-60 seconds</p> <p>Isolation: 1000Vrms between case, input, output (units with -AO option) and power, continuous, and will withstand a 1500Vac dielectric strength test for one minute without breakdown</p> <p>Line Voltage Effect: $\pm 0.005\%$ of span for a 1% change in line voltage (AC or DC)</p> <p>Power Consumption: 2-4W, nominal; 6W, maximum</p>	<p>Performance (continued)</p> <p>Input Impedance: 160 kohms for voltage inputs; 0.002 ohms for current inputs</p> <p>Input Over-Range Protection: Current: 7.5A rms continuous, 10A rms for $< 1.0\text{sec}$; Voltage: 264Vac</p> <p>Performance with Analog Output (-AO Option)</p> <p>WITH ANALOG OUTPUT Output Accuracy: $\pm 0.03\%$ of output span (includes the combined effects of linearity, hysteresis, repeatability, and adjustment resolution)</p> <p>Response Time: 250 msec maximum time for output to go from 10% to 90% for step change on input</p> <p>Ripple (up to 120Hz): Current output, 10mV peak-to-peak max. when measured across a 250 ohm resistor; Voltage output, 50mV peak-to-peak maximum</p> <p>Output Limiting: 117% of span maximum, 115% of span typical</p> <p>Load Effect: $\pm 0.01\%$ of span from 0 to maximum load resistance on current output</p> <p>Ambient Conditions</p> <p>Operating Range: -25°C to $+70^{\circ}\text{C}$ (-13°F to $+158^{\circ}\text{F}$)</p> <p>Storage Range: -40°C to $+85^{\circ}\text{C}$ (-40°F to $+185^{\circ}\text{F}$)</p> <p>Ambient Temperature Effect: $\pm 0.015\%$ of output span per $^{\circ}\text{C}$ maximum;</p>	<p>Ambient Conditions (continued)</p> <p>Relative Humidity: 0-95% non-condensing</p> <p>RFI/EMI Protection: 10V/m, 20 to 1000 MHz, as per SAMA 33.1 - ABC with 0.5% of span or less error</p> <p>Digital Filter: 50 or 60Hz (user-selectable)</p> <p>Common Mode Rejection: 100dB @ 50/60Hz</p> <p>Adjustments</p> <p>Front panel push buttons control settings for zero, span, alarm trip points, high/low alarms, etc.; Easy access internal settings select current (source or sink) or voltage output, and failsafe or non-failsafe alarm functions; Internal jumper and menu password protect parameter settings</p> <p>Indicators</p> <p>LCD: 2x4 character, backlit, alphanumeric readout accurate to the nearest digit</p> <p>Range: -9999 to 9999; Decimal point can be user-set when in Custom Mode</p> <p>LED's: Dual-color TRIP light (one for each relay) shows green for non-alarm, red for alarm; READY light indicates normal operation, extinguishes in the event of any internal failure; INPUT light is always green</p> <p>Weight 510 g (18 ounces)</p>
--	--	--

SPA

Site-Programmable Current/Voltage and RTD/Thermocouple Limit Alarm Trips

RTD, Thermocouple, Ohm, and mV Input Model

This SPA model accepts a direct input from RTD and thermocouple temperature sensors and other transmitters and transducers that output ohm or millivolt signals. It provides two or four relay outputs if the high and/or low limits you set are exceeded.

Analog Output Option

With the -AO (or -AOZ) option, the SPA provides an isolated and linearized retransmission of the analog output that can be sent to readout and control systems like a DCS, PC, indicator, or recorder.

Ordering Information

Unit	Input	Output	Power	Options	Housing
SPA Site-Programmable Alarm Trip	<p>TPRG Programs to accept low-level input signals (see Table 1 for details):</p> <p>RTD: 2-, 3-, and 4-wire; platinum, copper, and nickel (see Table 1 for details)</p> <p>Thermocouple: J, K, E, T, R, S, N, B</p> <p>Ohms: 0-4000 ohms</p> <p>Millivolts: -10 to 120mV</p>	<p>2PRG Dual Relays 4PRG Quad Relays (Single Relay and Triple Relay versions are also available. Consult the factory for details)</p> <p>Each relay individually configures for: High or Low Trip Normally Open or Normally Closed Failsafe or Non-Failsafe Latching or Non-Latching</p> <p>(Relays are single pole/double-throw (SPDT), 1 form C, rated 5A @ 250Vac, 50/60Hz or 24Vdc, non-inductive)</p>	<p>U Universal, 4-wire (line) power; accepts any power input range between 22-300Vdc or 90-260Vac</p> <p>For CE approved units, specify one of the following: 24DC ±10% 117AC ±10% 230AC ±10%</p>	<p>-AO Analog output (isolated and linearized) scaleable for any range between 4-20mA (4mA span, minimum) into 1200 ohms or 1-5V (1V span, minimum) into 10 kohms NOTE: Output can be user-set for internal or external power (source or sink)</p> <p>-AOZ Zero based analog output (isolated and linearized) programmable for either 0-20mA (4mA span, minimum) into 1200 ohms or 0-5V (1V span, minimum) into 10 kohms NOTE: Output can be user-set for internal or external power (source or sink)</p> <p>-DPDT Double-pole/double-throw relays, 2 form C relays, rated 5A @ 250Vac, 50/60Hz, non-inductive (1PRG and 2PRG output types only)</p> <p>-FMEDA Unit comes with Failure Modes, Effects and Diagnostic Analysis (FMEDA) data for evaluating the instrument for suitability of use in a safety-related application</p> <p>-HS Hermetically sealed relays, rated 0.5A @ 117Vac and 2A @ 28Vdc</p> <p>-SF3 Sensor Failure Alarm (3PRG and 4PRG output types only; see Page 9 for details)</p>	<p>DIN Universal DIN-style housing mounts on 32mm (EN50035) G-type and 35mm (EN50022) Top Hat DIN-rails</p>

Figure 8. RTD, T/C, Ohm, and mV Inputs (TPRG Input Type).

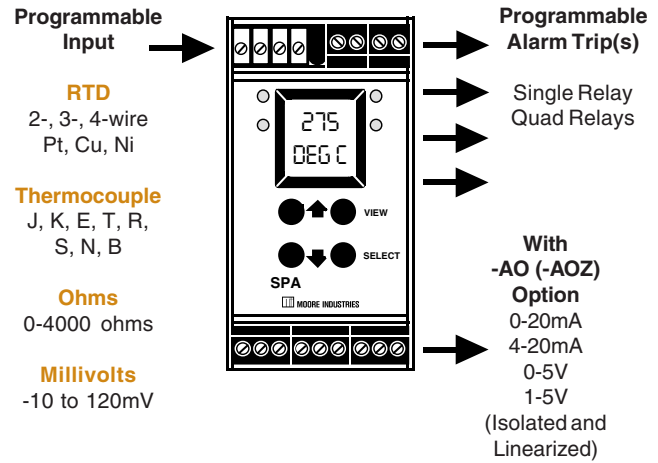

When ordering, specify: Unit / Input / Output / Power / Options [Housing]

Model number example: SPA / TPRG / 2PRG / U / -AOZ [DIN]

RTD, Thermocouple, Ohm, and Millivolt Input Model

Total Sensor Diagnostics

Our site-programmable SPA (TPRG model) performs continuous sensor diagnoses. This industry-first and patented Moore Industries feature may save you thousands in production costs, and hours of troubleshooting time, by letting you know when a problem occurs, and its type and location (Figure 9).

If an RTD wire breaks, the SPA trips its alarms to indicate trouble. Its trip LEDs turn from green to red, and if equipped with the -AO or -AOZ option, it sends the analog output either upscale or downscale (user-selectable).

Then our transmitters go a step further. A plain-English error message on the front panel LCD tells exactly where the problem has occurred. Specific error messages eliminate the work of removing the sensor or checking all lead wires to diagnose a problem. This advantage is especially valuable during startup.

Superior Reference Junction Compensation

Uncompensated plastic terminals are very susceptible to ambient temperature changes. Temperature changes may result in readings that are “off” by several degrees.

That’s why we don’t use ordinary plastic terminals on our temperature input SPA. We use far more stable metallic connection terminals.

Our metal terminals and advanced electronic compensation technique provide you with stable instrument performance you can rely on.

-SF3 Option Provides Failure Alarm, Without Shutdown, if Sensor Fails

When you need to know if you have a sensor failure, but you don’t want to trip process alarms or shutdown your process under that condition, the SPA with the -SF3 Sensor Failure Alarm option is your answer (Figure 10). Available on units with 4 relay (4PRG) output types, the SPA’s Relay #3 will trip on sensor failure only, without affecting the other two (or three) SPA relays being used to monitor a process.

Figure 9. Total Sensor Diagnostics Saves Troubleshooting Time.

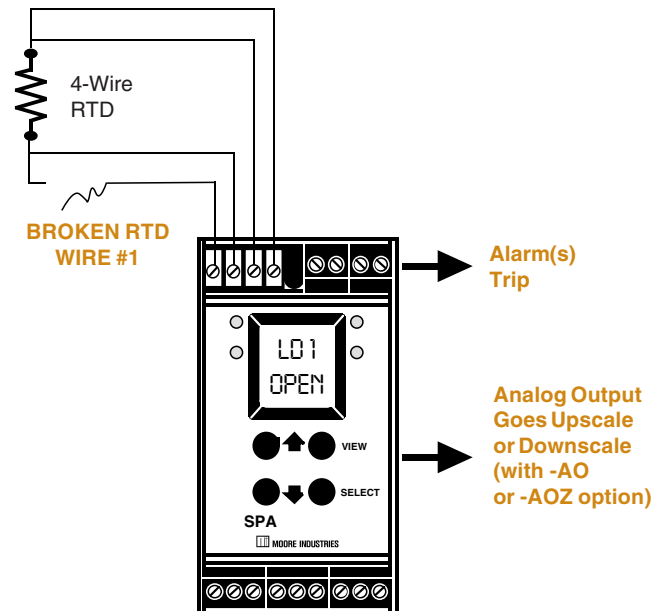
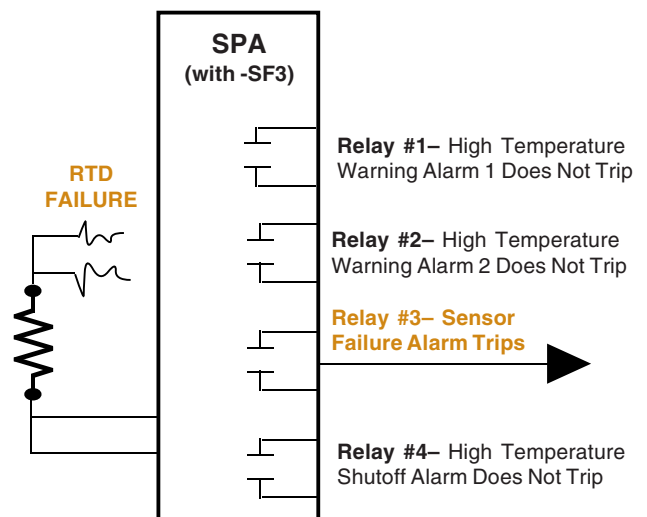

Figure 10. With the -SF3 option, in the event of a sensor failure only Relay #3 will trip to warn you of the condition.



SPA

Site-Programmable Current/Voltage and RTD/Thermocouple Limit Alarm Trips

Specifications (RTD, T/C, Ohm, and mV Input Model)

<p>Performance Repeatability: Trip point repeats within $\pm 0.05\%$ of input span Display Accuracy: ± 1 digit Input Accuracy: See Table 1 on following page Reference Junction Compensation Accuracy (T/C inputs only): $\pm 0.25^\circ\text{C}$ Stability: $\pm 0.1\%$ of calibrated span, maximum, over 6 months Deadband: User-set within selected input range; fully scaleable and set in user-selected engineering units Response Time: 700 milliseconds (Defined as time from step change on input to alarm state change when alarm is set to trip mid-point) Alarm Trip Delay: Programmable from 0-60 seconds Line Voltage Effect: $\pm 0.005\%$ of span for a 1% change in line voltage (AC or DC) Isolation: 1000Vrms between case, input, output (units with -AO or -AOZ option) and power terminals (NOTE: High voltage effect of $\pm 0.001\%$ of output span/V possible with prolonged exposure to AC voltage above 200Vac) Power Consumption: 2-3.5W, nominal; 4.3W, maximum Input Failure (Burnout) Protection: On detected input failure, all relays switch to alarm state (unless -SF3 option is specified, then only relay #3 trips); front panel push buttons select HI/LO</p>	<p>Performance (continued) alarms and upscale or downscale drive if equipped with -AO or -AOZ option Input Impedance: 10 Mohms for T/C and mV inputs Input Over-Range Protection: $\pm 5\text{Vdc}$; 180% of maximum input span</p> <p>Performance with Analog Output (-AO Option) WITH ANALOG OUTPUT Output Accuracy: $\pm 0.03\%$ of output span (includes the combined effects of linearity, hysteresis, repeatability, and adjustment resolution) Response Time: 400ms maximum time for output to go from 10% to 90% for step change on input Ripple (up to 120Hz): Current output, 10mV peak-to-peak maximum when measured across a 250 ohm resistor; Voltage output, 15mV peak-to-peak maximum Output Limiting: 117% of span maximum, 115% of span typical Load Effect: $\pm 0.01\%$ of span from 0 to maximum load resistance on current output</p> <p>Ambient Conditions Operating Range: -25°C to $+65^\circ\text{C}$ (-13°F to $+149^\circ\text{F}$) Storage Range: -40°C to $+80^\circ\text{C}$ (-40°F to $+176^\circ\text{F}$) Relative Humidity: 0-95% non-condensing Ambient Temperature Effect: $\pm 0.005\%$ of output span per $^\circ\text{C}$ maximum; $\pm 15\text{ppm}$ of input signal</p>	<p>Ambient Conditions (continued) Effect of Ambient Temperature on Reference Junction Compensation (T/C inputs only): $\pm 0.05\%$ per 50°C change in ambient temperature RFI/EMI Protection: 30V/m- ABC $\leq 0.5\%$ error in reading when tested according to SAMA standard PMC 33.1 Common Mode Rejection: 100dB @ 60Hz Normal Mode Rejection: 40dB @ 60Hz</p> <p>Adjustments Front panel push buttons control settings for zero, span, alarm trip points, high/low alarms, etc.; Easy access internal settings select current (source or sink) or voltage output, and failsafe or non-failsafe alarm functions; Internal jumper and menu password protect parameter settings</p> <p>Indicators LCD: 2x4 character, backlit, alphanumeric readout accurate to the nearest digit. Range: -9999 to 9999 LED's: Dual-color TRIP light (one for each relay) shows green for non-alarm, red for alarm; READY light indicates normal operation, extinguishes in the event of any internal failure; Dual-color INPUT light shows green for input with rated range, red for over range and sensor/wire failure</p> <p>Weight 456 to 513 g (16.1 to 18.1 oz)</p>
--	---	---

Table 1. SPA Accuracy with RTD, Thermocouple, Ohms, and Millivolt Inputs.

Input Type					
Selection	α	Ohms	Range	Accuracy	Minimum Span ₂
Pt RTD	3750	1000	-185°C to 540°C (-301°F to 1004°F)	±0.1°C	Single, 100 ohm Sensor, 15°C Averaging 100 ohm Sensors, 15°C Differential of 100 ohm Sensors, 30°C Single, 200 ohm Sensor, 10°C Averaging 200 ohm Sensors, 10°C Differential of 200 ohm Sensors, 20°C Single, 500 or 1000 ohm Sensor, 7.5°C Averaging 500 or 1000 ohm Sensors, 7.5°C Differential of 500 or 1000 ohm Sensors, 15°C
	3850	100, 200, 300, 400, 500, 1000	-200°C to 850°C (-328°F to 1742°F)	100 ohms: ±0.2°C; 200, 300 & 400 ohms: ±0.15°C; 500 & 1000 ohms: ±0.1°C	
	3902	100, 200, 400, 500, 1000	-100°C to 650°C (-148°F to 1201°F)	100 ohms: ±0.2°C; 200 & 400 ohms: ±0.15°C; 500 & 1000 ohms: ±0.1°C	
	3911	100, 500	-200°C to 630°C (-328°F to 1166°F)	100 ohms: ±0.2°C; 500 ohms: ±0.1°C	
	3916	100	-200°C to 510°C (-328°F to 950°F)	±0.2°C	
	3923	98.129	-200°C to 600°C (-328°F to 1112°F)	±0.2°C	
	3926	100, 200, 470, 500	-200°C to 630°C (-328°F to 1166°F)	200 to 470 ohms: ±0.15°C; 500 ohms: ±0.1°C	
	3928	100	-200°C to 850°C (-328°F to 1742°F)	±0.2°C	
Ni RTD	672	120	-80°C to 320°C (-112°F to 608°F)	±0.14°C	Single Sensor, 10°C Averaging Sensors, 10°C Differential of Multiple Sensors, 20°C
Cu RTD	427	9.035	-50°C to 250°C (-58°F to 482°F)	±1.6°C	Single Sensor, 100°C Averaging Sensors, 100°C Differential of Multiple Sensors, 200°C
Ohms			0-4000 ohms	±0.4 ohms	30 ohms
Range Linear Conformance Range Accuracy Minimum Span ₂					
T/C J		-210°C to +770°C (-346°F to +1418°F)	-180°C to 760°C (-292°F to 1400°F)	±0.25°C	35°C
T/C K		-270°C to +1390°C (-454°F to +2534°F)	-150°C to 1370°C (-238°F to 2498°F)	±0.3°C	40°C
T/C E		-270°C to +1013°C (-454°F to +1855.4°F)	-170°C to 1000°C (-274°F to 1832°F)	±0.25°C	35°C
T/C T		-270°C to +407°C (-454°F to +764.6°F)	-200°C to 400°C (-328°F to 752°F)	±0.25°C	35°C
T/C R		-50°C to +1786°C (-58°F to +3246.8°F)	0°C to 1760°C (-32°F to 3200°F)	±0.5°C	50°C
T/C S		-50°C to +1786°C (-58°F to +3246.8°F)	0°C to 1760°C (-32°F to 3200°F)	±0.5°C	50°C
T/C N		-270°C to +1316°C (-454°F to +2400.8°F)	-130°C to 1300°C (-202°F to 2372°F)	±0.4°C	45°C
T/C B		+200°C to +1836°C (+392°F to +3336.8°F)	+400°C to 1820°C (+752°F to 3308°F)	±0.8°C	75°C
Voltage - mV		-10 to +120mV		±15microvolts	4mV

1. Actual α is 0.003750, 0.003850, etc.

2. Recommended Minimum Span. Tighter spans may result in output inaccuracies.

SPA

Site-Programmable Current/Voltage and RTD/Thermocouple Limit Alarm Trips

Table 2. Determining unit dimensions.

Signal Input Type	Number of Relays	With -CE Option*	Use Dimension Figure
HLPRG	1	No	11
	1	Yes	13
	2	No	11
	2	Yes	13
	3	No	12
	3	Yes	13
	4	No	12
	4	Yes	13
TPRG	1	No	11
	1	Yes	13
	2	No	11
	2	Yes	13
	3	No	12
	3	Yes	13
	4	No	12
	4	Yes	13
ACVPRG	1	No	14
ACIPRG	1	Yes	14
	2	No	14
	2	Yes	14

* Units with -CE option are CE conformant per EMC Directive 89/336/EEC; EN 50081-1, 1993 and EN50082-1, 1995

Figure 11. Installation dimensions (see Table 2).

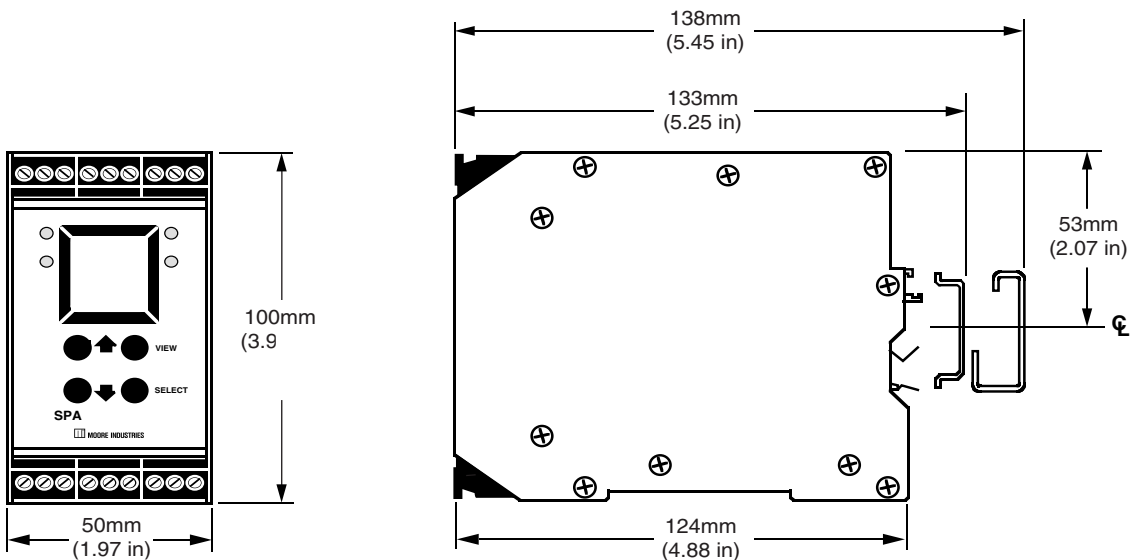

Figure 12. Installation dimensions (see Table 2).

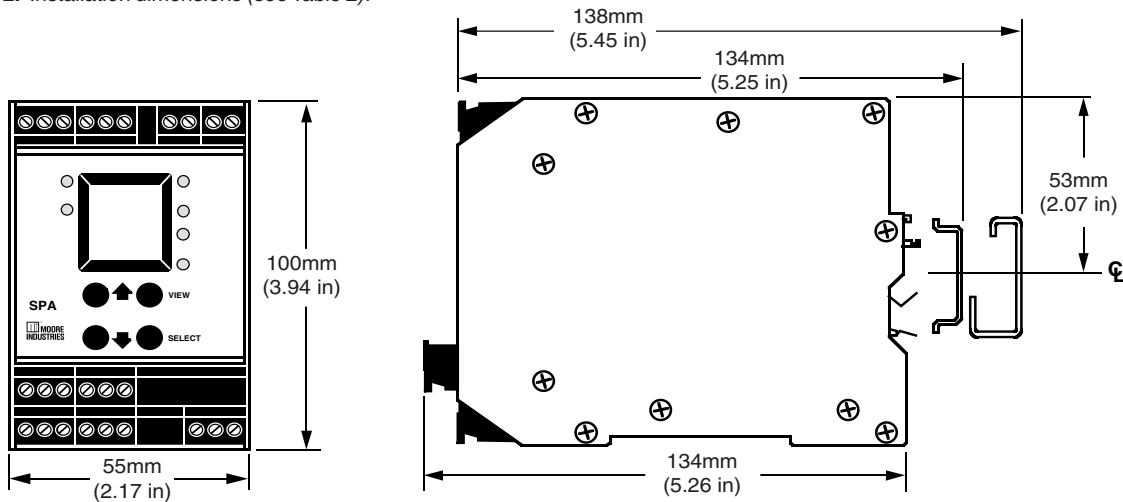

Figure 13. Installation dimensions (see Table 2).

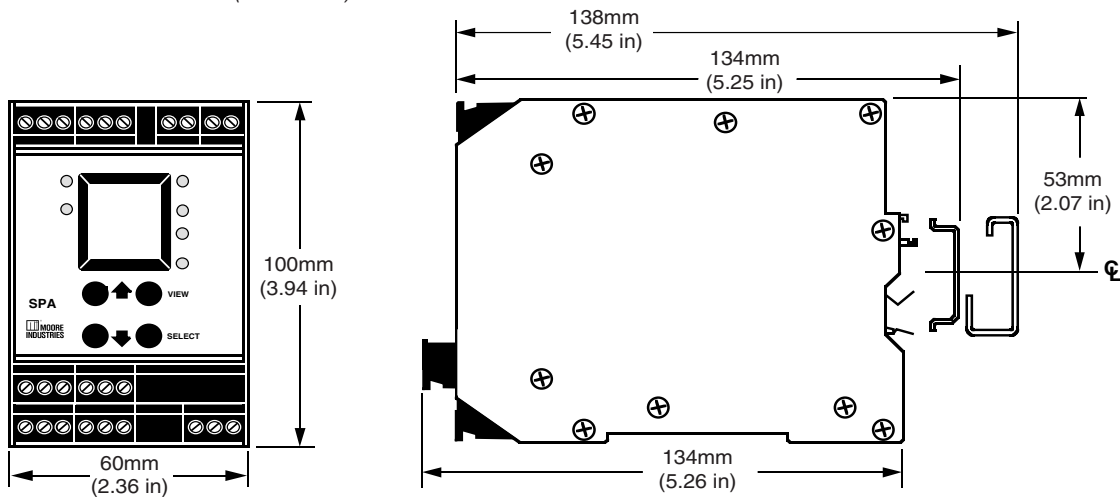
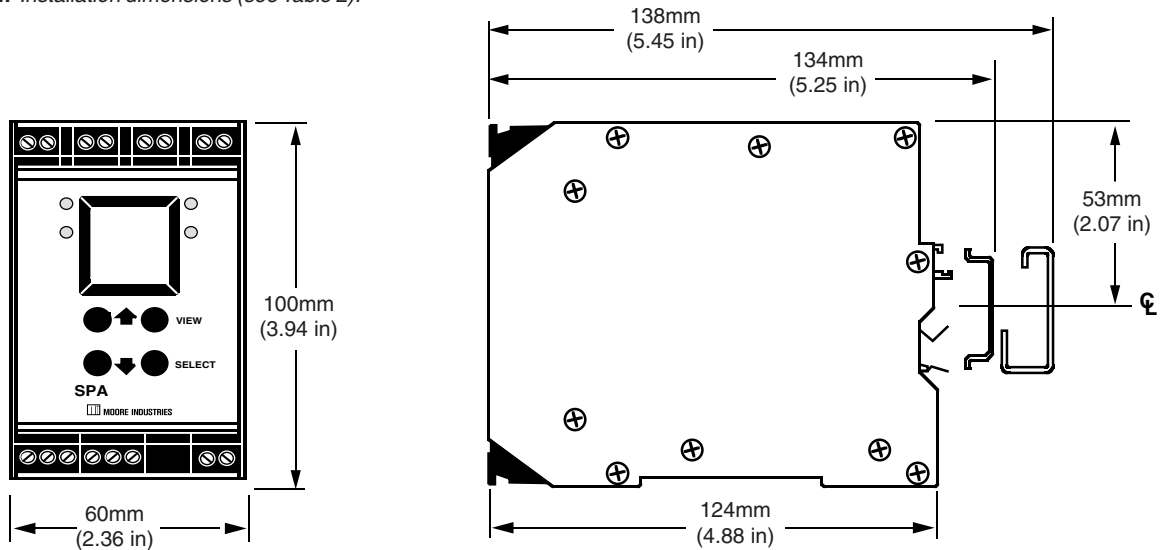

Figure 14. Installation dimensions (see Table 2).



SPA

Site-Programmable Current/Voltage and RTD/Thermocouple Limit Alarm Trips

Table 3. Terminal Designations (see Figures 15 and 16 for additional information).

INPUT	T1	T2	T3	T4	T5	T6	T7	T8	T9	T10	T11
TPRG Input						MR		+AO	-AO	not present	not present
TPRG Input with 3PRG or 4PRG, or with 1PRG or 2PRG and DPDT	+	-	no label	no label	not present	not present	MR	MR	+AO	-AO	
TPRG Input with 3PRG or 4PRG & CE, or with 1PRG or 2PRG & DPDT &/or CE									not present	+AO	-AO
HLPRG Input						MR		+AO	-AO	not present	not present
HLPRG Input with 3PRG or 4PRG, or with 1PRG or 2PRG and DPDT	+I, +V	-I	-V	+TX	+I	not present	MR	MR	+AO	-AO	
HLPRG Input with 3PRG or 4PRG & CE, or with 1PRG or 2PRG & DPDT & CE									not present	+AO	-AO
ACIPRG & ACVPRG	•Ia, •Va	Ia, Va	not present	+RUN	-RUN	not present	MR+	MR-	not present	+AO	-AO
OUTPUT	M1	M2	M3	M4	M5	M6	M7	M8	M9	M10	M11
Any Single Alarm (1PRG) w/DPDT	NO2	CM2 relay1	NC2	not present			not present				
Any Dual Alarm (2PRG) w/DPDT	NO2	CM2 relay1	NC2	NO2	CM2 relay2	NC2					
Any Triple Alarm (3PRG)	NO3	CM3 relay3	NC3	not present							
Any Quad Alarm (4PRG)	NO3	CM3 relay3	NC3	NO4	CM4 relay4	NC4					
OUTPUT / POWER	B1	B2	B3	B4	B5	B6	B7	B8	B9	B10	B11
Single Alarm (1PRG)	NO	CM	NC	not present			Power AC DC	Power AC DC	GND	not present	not present
Single Alarm (1PRG) w/DPDT only	NO1	CM1	NC1				GND				
Single Alarm (1PRG) w/CE and/or HART	NO	CM	NC				Power AC DC	Power AC DC			
Single Alarm (1PRG) w/DPDT and/or HART	NO1	CM1	NC1				Power AC DC	GND			
Dual Alarm (2PRG)	NO1	CM1 relay1	NC1	NO2	CM2 relay2	NC2	Power AC DC	Power AC DC	GND	not present	not present
Dual Alarm (2PRG) w/DPDT only	NO1	CM1 relay1	NC1	NO1	CM1 relay2	NC1	not present	Power AC DC	GND		
Dual Alarm (2PRG) w/DPDT and/or HART	NO1	CM1 relay1	NC1	NO1	CM1 relay2	NC1	not present	Power AC DC	Power AC DC	Power AC DC	GND
Triple Alarm (3PRG)	NO1	CM1 relay1	NC1	NO2	CM2 relay2	NC2	not present	Power AC DC	Power AC DC	GND	not present
Triple Alarm (3PRG) w/CE and/or HART	NO1	CM1 relay1	NC1	NO2	CM2 relay2	NC2	not present	Power AC DC	Power AC DC	Power AC DC	GND
Quad Alarm (4PRG)	NO1	CM1 relay1	NC1	NO2	CM2 relay2	NC2	not present	Power AC DC	Power AC DC	GND	not present
Quad Alarm (4PRG) w/CE and/or HART	NO1	CM1 relay1	NC1	NO2	CM2 relay2	NC2	not present	Power AC DC	Power AC DC	Power AC DC	GND

NOTES:

- Terminal blocks can accommodate 14-22 AWG solid wiring.
- Polarity shown for T1 and T2 of TPRG unit applies to thermocouple inputs only.
- ±MR and ±AO labeling is present only when the unit is equipped with those options.

KEY:		
MR = Manual Reset	AO = Analog Output	I = Current Input
INA/B = Current input from HART transmitter	NO/NO# = Normally Open	GND = Ground
NC/NC# = Normally Closed	TXA/B = Power for 2-wire transmitter	V = Voltage Input
DPDT = Double-pole/Double-throw	CM/CM# = Common	TX = Power for 2-wire transmitter

Figure 15. Terminal position and sensor hook-up guides.

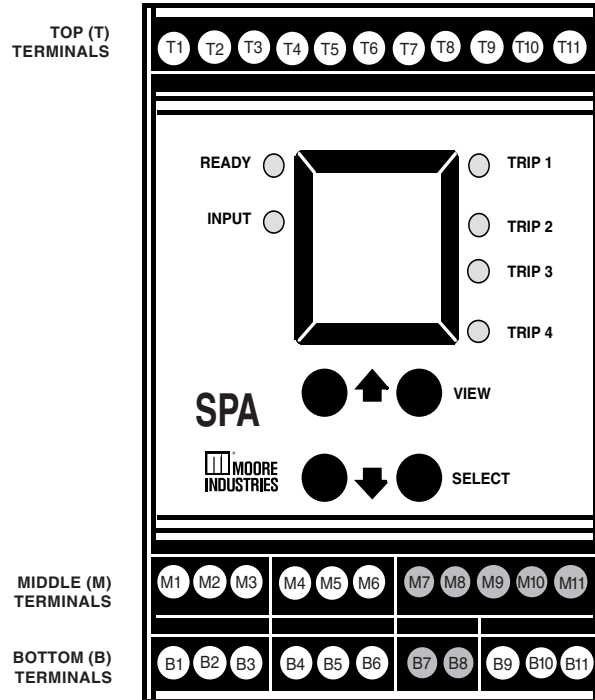
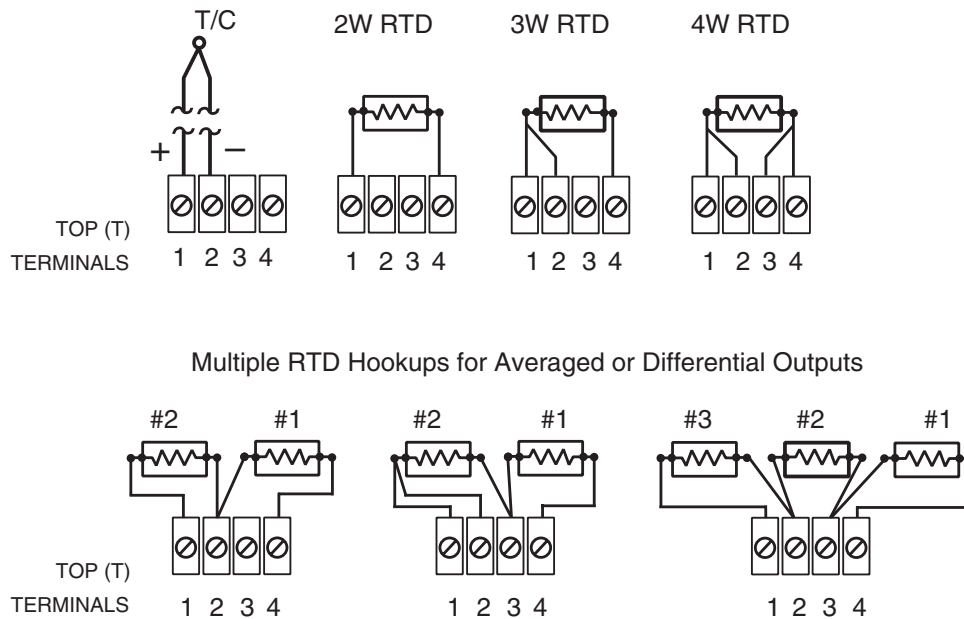

Figure 16. Temperature sensor hook-up guide for TPRG units.



NOTE: In Differential Measurement applications always connect sensor to be used as "high" to terminals shown here as Sensor #1.

SPA

Site-Programmable Current/Voltage
and RTD/Thermocouple Limit Alarm Trips

Six Instruments in One!

- 1 Single, Dual, Triple, or Quadruple Limit Alarm Trip
- 2 Analog or Temperature Transmitter
- 3 Signal Isolator and Converter
- 4 Local Process Display in Engineering Units
- 5 Linearization, Averaging, and Differential Computation Module
- 6 2-Wire Transmitter Power Supply (Transmitter Excitation)

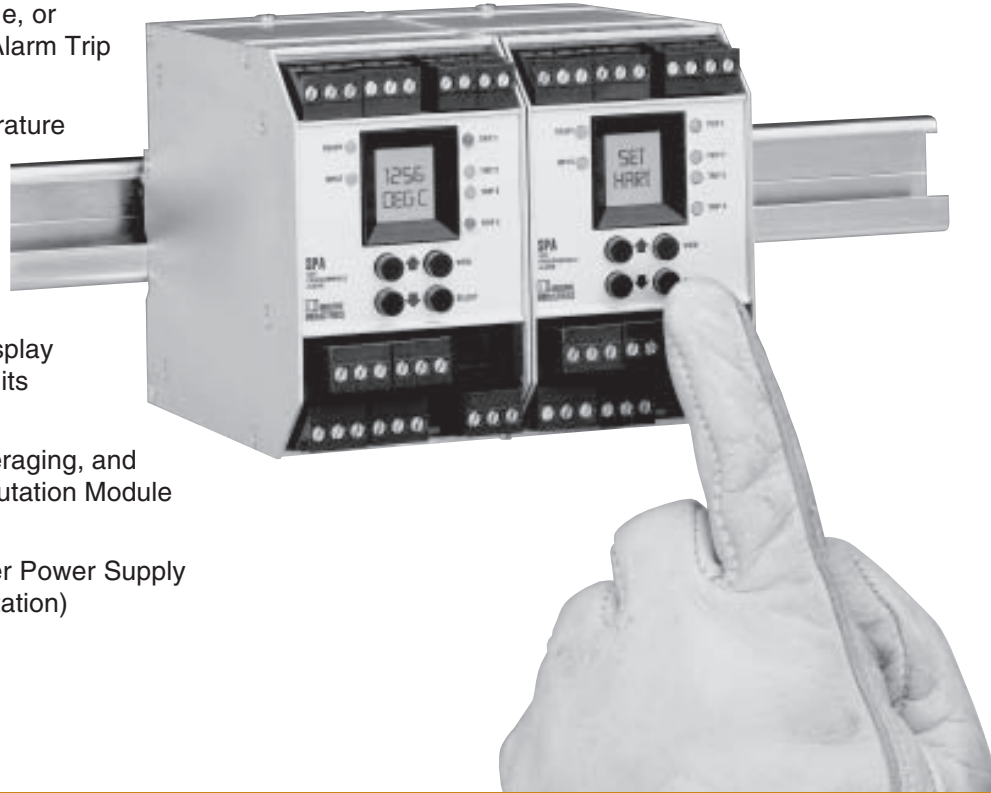

Universal Alarm Trip Solution

There's no need to specify and stock an array of single-function alarm trips. Our SPA is the perfect solution:

- Standardize on, and stock just one, universal instrument for all of your alarm trip needs.
- Warn of trouble by providing an alarm output when a process signal exceeds a high and/or low limit.
- Provide dependable, redundant warning and/or shutdown capabilities to compensate for a DCS or PLC failure.
- Use combination alarm trip/transmitter SPAs to reduce costs when both alarming and monitoring functions are needed at the same location.
- Sense dangerous conditions and shut down control equipment before it is damaged.
- Compare two variables and trip an alarm when the difference between the two exceeds a preset value.
- Install multi-trip alarms to provide several levels of warning and shutdown action.
- Use for reliable and cost-effective on/off control of pumps and motors.
- Create custom, 22 point linearization curves to compensate for non-linear measurements and instruments.
- Keep track of sensor operation and quickly diagnose sensor failures with our patented *Total Sensor Diagnostics*.



United States • info@miinet.com
Tel: (818) 894-7111 • FAX: (818) 891-2816
Australia • sales@mooreind.com.au
Tel: (02) 8536-7200 • FAX: (02) 9525-7296

Belgium • info@mooreind.be
Tel: 03/448.10.18 • FAX: 03/440.17.97
The Netherlands • sales@mooreind.nl
Tel: (0)344-617971 • FAX: (0)344-615920

China • sales@mooreind.sh.cn
Tel: 86-21-62481120 • FAX: 86-21-62490635
United Kingdom • sales@mooreind.com
Tel: 01293 514488 • FAX: 01293 536852

The Interface Solution Experts • www.miinet.com