

Description

The versatile SIX can be used as a signal isolator, converter, and repeater. Ideal for installation in the plant and control room, the 2-wire (loop-powered) SIX derives its power from the process loop, eliminating the need to install an additional power supply.

Isolator—The SIX provides total isolation between the signal from a non-isolated transmitter and a receiving device. This eliminates faulty readings in process measurement and control equipment caused by ground loops, motor noise, and other electrical interference.

Converter—Acting as a precise interface, the SIX allows transmitters, transducers, controllers, recorders, and control systems with dissimilar signals to communicate with one another.

Repeater/Diverter—The SIX can be used to increase drive capability to a process loop, allowing installation of additional instruments on the loop. The SIX also is excellent for “diverting” a secondary signal from a process loop to a recorder, indicator, or other similar device.

Solves “Bucking Power Supplies”

Many plants encounter problems when trying to interface a DCS with a 4-wire (line-powered) transmitter. Both units are supplying power to the same loop, which results in “Bucking Power Supplies” and a non-functioning loop. If neither power supply can be eliminated, install a SIX between the two. It operates with powered inputs from both sides, thus restoring normal operations to the loop.

Figure 1. The SIX provides isolation between a non-isolated transmitter and a receiving device.

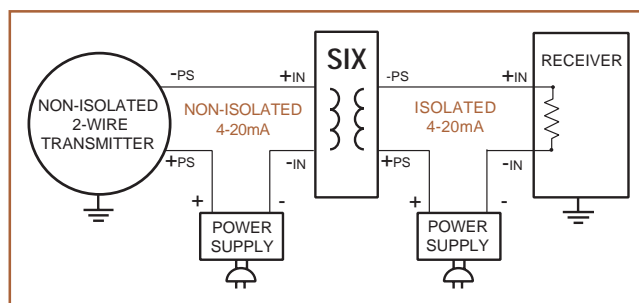

The SIX's DIN-style housing mounts quickly and easily on G-type and Top Hat rails. Removable terminal blocks speed installation and maintenance.

Features

- **Stops ground loops.** Complete isolation stops ground loops from affecting the integrity of a transmitted process signal.
- **Wide range of inputs and outputs.** Available models offer input and output combinations to handle common and unusual applications.
- **Low current impedance/high drive capability.** The SIX's exceptionally low 50Ω (for 4-20mA input) impedance doesn't load existing loops and regenerates signals.
- **RF/EMI protection.** Inherent 10V/m immunity protects the SIX in most applications. For especially noisy environments, choose the -RF option which provides superior 50V/m protection.

Certifications



Factory Mutual Research Corporation (FMRC)
Non-Incendive
 Class I, Division 2, Groups A, B, C, D
Suitable for:
 Class II, Division 2; Class III, Divisions 1 & 2



Canadian Standards Association (CSA)
 General (Ordinary) Location; NRTL/C



CE Conformant EMC Directive 89/336/EEC EN 50081-2, 1993; 50082-2, 1995.

SIX

2-Wire Signal
Isolator/Converter

Specifications

Performance	Accuracy: ±0.1% of span	Performance (continued)	Load Capability: $\frac{V_s - 12V}{0.02A} = \text{ohms}$	Ambient Temperature	Range: -30°C to +82°C (-22°F to +180°F)
	Linearity: ±0.1% of span		Power Supply Effect: <0.05% of span over the full power supply range		Effect: ±0.015% of span/°C change over 0-70°C range (±0.008% of span/°F over +32°F to +158°F range)
	Isolation: Input and output transformer isolated up to 500Vrms		RFI/EMI Effect: Negligible effect @ 10V/m at popular walkie-talkie frequencies (for enhanced protection, see the -RF option)	Adjustments	Type: External multturn potentiometers
	Maximum Input Over Range: ±60V				Span: ±10% of span
	Input Impedance: 50Ω for 4-20mA input; 1KΩ for -1mA to 1mA input; 1.0MΩ for voltage inputs 10V and below				Zero: ±5% of span
				Weight	215 grams (7.6 ounces)

Ordering Specifications

Unit	Input	Output	Power	Options	Housing
SIX	0-20MA into 50Ω 4-20MA into 50Ω 10-50MA into 20Ω 0-1MA into 1KΩ -1TO+1mA into 1KΩ .2-1V into 1MΩ 0-1V into 1MΩ 0-5V into 1MΩ 1-5V into 1MΩ 0-10V into 1MΩ -10VTO+10V into 200KΩ (-BI option required) 0-30V into 200KΩ (-ATL option required)	4-20MA into 600Ω ohms with 24Vdc power supply 10-50MA into 600Ω with 42Vdc power supply	12-42DC (loop-powered on output side)	-ATL Low-impedance attenuated input (must be specified with inputs greater than 10V) -BI Bailey input (must be specified with -10VTO+10V input type) -RF RFI/EMI protection rates 50V/m - ABC = ±0.1% F.S. when tested according to SAMA Standard PMC 33.1	DIN DIN-style housing mounts on 32mm G-type (EN50035) and 35mm Top Hat (EN50022) rails

To order, specify: Unit / Input / Output / Power / Options [Housing]

Model Number Examples: SIX / 4-20MA / 4-20MA / 12-42DC / -RF [DIN]

Figure 2. Installation Dimensions and Terminal Designations.

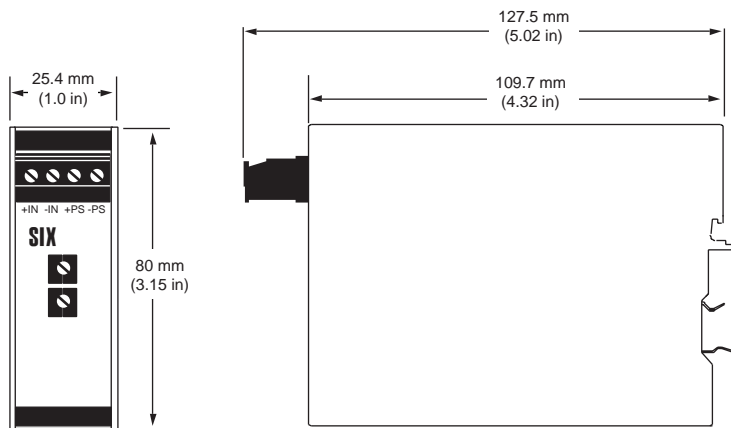

The Interface Solution Experts • www.miinet.com

United States • info@miinet.com
Tel: (818) 894-7111 • FAX: (818) 891-2816
Australia • sales@mooreind.com.au
Tel: (02) 9525-9177 • FAX: (02) 9525-7296

Belgium • mii.belgium@pandora.be
Tel: 03/448.10.18 • FAX: 03/440.17.97
The Netherlands • sales@mooreind.demon.nl
Tel: (0)344-617971 • FAX: (0)344-615920

China • sales@mooreind.com.cn
Tel: 86-21-58313053 • FAX: 86-21-68752927
United Kingdom • sales@mooreind.com
Tel: 01293 514488 • FAX: 01293 536852