

**Now with Dual I/O Channels**

## Description

The ECT family of signal isolators and converters delivers economical solutions for a wide variety of signal interface applications.

**Isolator**—The ECT provides total signal isolation between a non-isolated transmitter and a receiving device. This eliminates faulty readings in process measurement and control equipment caused by ground loops, motor noise, and other unpredictable electrical interference.

**Converter**—A precise interface, the ECT accurately converts signals, such as 1-5V (dc) or 0-5A (ac), to a proportional 4-20mA signal typically needed by a controller, recorder, indicator, PLC, DCS, or PC-based SCADA system.

**Splitter**—When the output from one transmitter needs to be isolated and sent to two separate locations, such as in pipeline custody transfer applications, dual channel ECTs are your answer (see page 6).

**Booster**—Featuring low 25Ω input impedance (2-wire, output-loop powered model with 4-20mA input), the ECT can be used to increase drive capability in a process loop, allowing installation of additional instruments on the loop.

*To choose the right ECT for your application, first determine power supply characteristics:*

Power Supply Type	Page
2-Wire, Output-Loop Powered (12-42Vdc)	2-3
2-Wire, Input-Loop Powered (5.5VLP, 8.5VLP)	4
4-Wire, Line (Mains) Powered	5-7



**Compact thermoplastic DIN-style housing snaps** quickly and securely on to standard G-type and Top Hat rails

## Features

- **Superior signal isolation.** Industrial-strength 1500Vrms protection stops the harmful effects of even severe ground loop interference (input-loop powered ECTs provide 500Vrms isolation).
- **Common inputs and outputs.** Available models handle the current and voltage signal types most needed throughout your plant.
- **2-wire and 4-wire models.** Loop-powered and line (mains) powered models provide cost-effective alternatives for a wide array of field and control room applications.
- **Get two isolators in one.** The ECT is available in dual channel I/O models that provide application flexibility while reducing space requirements and costs (see page 6).
- **Low-cost DCS troubleshooter.** Solve start-up problems caused by non-isolated transmitters by installing an ECT in each troublesome loop.

### Certifications



**Underwriter's Laboratories:** General Location



**CE:** Conformant to EMC 89/336/EEC EN 50081-2, 1993, 50082-2, 1995

### 2-Wire, Output-Loop Powered Models

Easy to install in the field, the 2-wire, Output-Loop Powered ECT derives its operating power from the output side of the process loop via a 24Vdc power supply (Figure 1).

#### Solves “Bucking” Power Supplies

Many plants encounter problems when trying to interface a DCS with a 4-wire (line-powered) transmitter when both units are supplying power to the same loop. This results in “bucking” power supplies and a non-functioning loop.

If neither power supply can be eliminated, install a 2-wire, output-loop powered ECT between the two. It can operate with powered inputs from both sides, thus restoring normal loop operation.

Figure 1. 2-Wire, Output-Loop Powered ECT

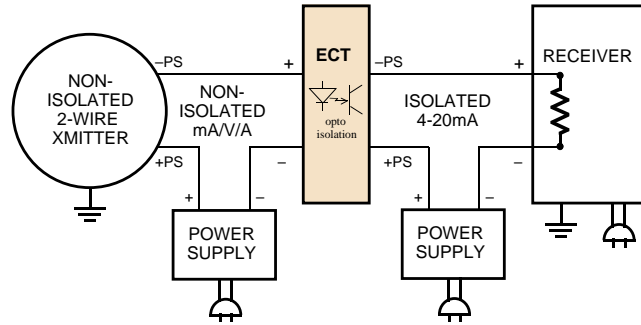

#### Step Down Unsafe High Level Signals

To protect plant personnel, the ECT comes with an optional external input transformer (-EM option) to step down high level AC current inputs to a low-level signal (Figure 2). This permits safer servicing without opening the secondary of the customer's current transformer.

Figure 2. 2-Wire, Output-Loop Powered ECT with Externally-Mounted Current Transformer (-EM Option)

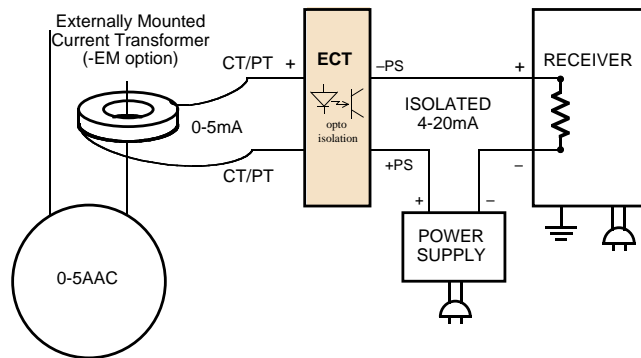

#### Innovative “Pass Power” Advantage

The Output-Loop Powered ECT with the 4-20MATX input type breaks the galvanic path between an output-loop powered 2-wire transmitter and a receiving device, but still transfers signals and loop power between the two without interruption (Figure 3). This advantage means the ECT can be installed as a “loop troubleshooter” with minimal loop alterations. You won't need to add a power supply between the ECT and the 2-wire transmitter, or specify a more expensive 4-wire transmitter with loop excitation capability.

Figure 3. The ECT with the 4-20MATX Input Type

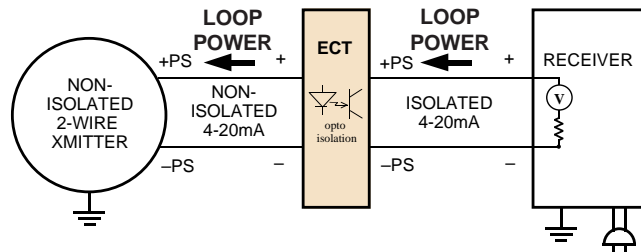

#### Power Supply Sharing

Multiple ECT loops with the 4-20MATX input type can be powered by one 24Vdc supply, saving you power supply costs and installation time (Figure 4).

## 2-Wire, Output-Loop Powered Models (continued)

### Specifications

#### 2-Wire, Output-Loop Powered Models

<p><b>Performance</b></p> <p><b>Accuracy:</b> DC inputs: ±0.1% of span; AC inputs: ±0.5% of span</p> <p><b>Isolation:</b> 1500Vrms between input and output</p> <p><b>Common Mode Rejection:</b> Exceeds 95dB at 60Hz with a limit of 1,500Vrms</p> <p><b>Input Overrange:</b> 250% of full scale for dc current inputs; 200V peak max. for dc voltage inputs; 20AAC peak for 1 sec., 10AAC continuous for ac current inputs; 600V peak max. for ac voltage inputs</p>	<p><b>Performance (continued)</b></p> <p><b>Output Current Limiting:</b> 25mA typical; 30mA max.</p> <p><b>Ripple:</b> 10mV (measured across 250Ω resistor)</p> <p><b>Burden:</b> 4V typical with 4-20MATX input; 0.5V max. with 4-20mA input; 0.01V max. with 0-5AAC input</p> <p><b>Load Capability:</b>  <math display="block">\frac{V_s - 12V_{dc}}{20mA} = R_{Load}</math>                     (Except 4-20MATX input)</p> <p><b>Response Time:</b> 100msec max. to 99% of output (400msec to 99% of output max. for 0-5A input)</p>	<p><b>Ambient Conditions</b></p> <p><b>Temperature Range:</b> -20°C to +70°C (-4°F to +158°F)</p> <p><b>Effect:</b> ±0.007% of span/°C typical; ±0.015% of span/°C max.</p> <p><b>Humidity:</b> 0-95% non-condensing</p> <p><b>Adjustments</b></p> <p><b>Type:</b> Front panel pots</p> <p><b>Span:</b> ±10%</p> <p><b>Zero:</b> ±5% (non-interactive when span is set first)</p> <p><b>Weight</b> 85 g (3 oz)</p>
--	---	--

### Ordering Information

Unit	Input	Output	Power	Options	Housing
ECT 2-wire (Output-Loop Powered) Isolator/ Converter	<b>4-20MA</b> into 25Ω <b>4-20MATX</b> (24-42DC power required) <b>1-5V</b> into 1MΩ <b>0-10V</b> into 1MΩ <b>0-150AC</b> into 100KΩ <b>0-250AC</b> into 160KΩ <b>0-5AAC</b> into 0.002Ω (Other ranges also available)	<b>4-20MA</b> into 600Ω with 24Vdc power supply	<b>12-42DC</b> <b>24-42DC</b> (specify with 4-20MATX input)	<b>-EM</b> Externally-mounted input transformer for current input (available with 0-5A (ac) input type only)	<b>ECD</b> Thermoplastic, DIN-style housing mounts on 32 mm G-type (EN50035) and Top Hat (EN50022) rails

**When ordering, specify:** Unit / Input / Output / Power / Options [Housing]

**Model number example:** ECT / 4-20MA / 4-20MA / 12-42DC [DIN]

**Figure 4.** Multiple ECTs with the 4-20MATX input type can be powered by one 24Vdc power supply.

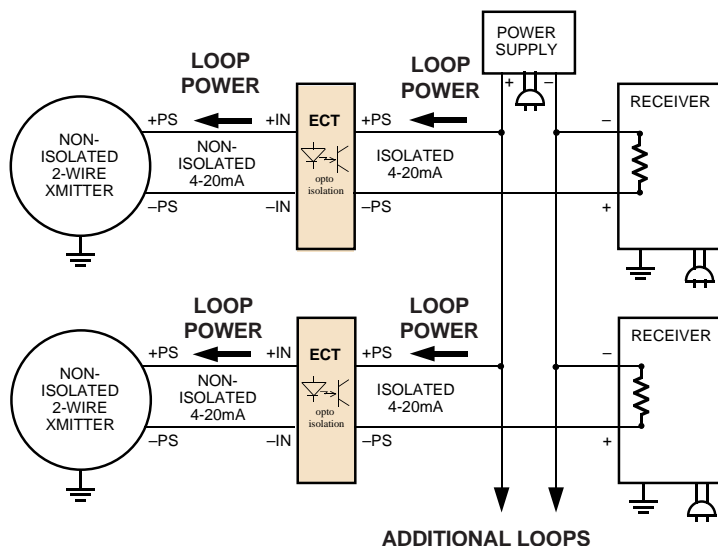

# ECT

## Signal Isolator/Converter

### 2-Wire, Input-Loop Powered Models

The 2-Wire, Input-Loop Powered ECT derives its operating power from the input side of the process loop (Figure 5). This model provides loop isolation when line power or output-loop power is not available.

Its simple hook-up method provides cost-effective interface between field signals and a computer, DCS or other multiple-input system.

Of special consideration when choosing this type of isolator is the total load imposed on the input loop. Because it derives all operating power from the input loop, that loop must be able to handle the isolator's input impedance and output load (maximum output load is 250Ω).

Figure 5. 2-Wire, Input-Loop Powered ECT

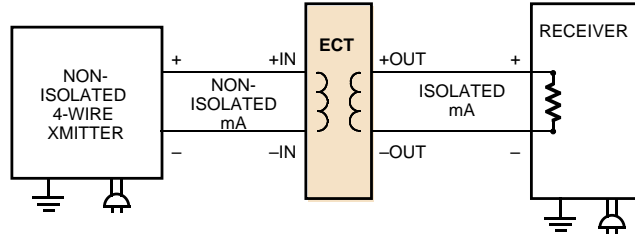

## Specifications

### 2-Wire, Input-Loop Powered Models

<p><b>Performance</b></p> <p><b>Accuracy:</b> ±0.075% of span</p> <p><b>Isolation:</b> 500Vrms between input and output</p> <p><b>Common Mode Rejection:</b> Exceeds 95dB at 60Hz with a limit of 500Vrms</p> <p><b>Input Overrange:</b> 200% of full scale for 4-20mA inputs; 150% of full scale max. for 10-50mA inputs</p> <p><b>Output Current Limiting:</b> 30mA max. with 250Ω output load</p>	<p><b>Performance (continued)</b></p> <p><b>Ripple:</b> 10mV (measured across 250Ω resistor)</p> <p><b>Load Effect:</b> Less than 0.25% per 10Ω change</p> <p><b>Burden:</b> 5.5V when outputs are shorted for 4-20mA inputs, 10.5V with 250Ω load; 8.5V when outputs are shorted for 10-50mA inputs, 13.5V with 100Ω load (Output load voltage is reflected on input. Output should be trimmed for anticipated output load)</p> <p><b>Response Time:</b> 20msec max. to 99% of output</p>	<p><b>Ambient Conditions</b></p> <p><b>Temperature Range:</b> -29°C to +82°C -20°F to +180°F</p> <p><b>Effect:</b> ±0.018% of span/°C; ±0.005% of span/°C gain change</p> <p><b>Humidity:</b> 0-95% non-condensing</p> <p><b>Adjustments</b></p> <p><b>Type:</b> Front panel pots</p> <p><b>Trim:</b> ±1%</p> <p><b>Weight</b></p> <p>85 g (3 oz)</p>
--	--	---

## Ordering Information

Unit	Input	Output	Power	Options	Housing
<b>ECT</b> 2-wire (Input-Loop Powered) Isolator/ Converter	<b>4-20MA</b> into 275Ω <b>10-50MA</b> into 150Ω	<b>4-20MA</b> into 0-250Ω <b>10-50MA</b> into 0-100Ω (10-50MA output requires 10-50MA input)	Current Loop Excitation at 4mA: <b>5.5VLP</b> 5.5 volts loop powered with 4-20mA (plus voltage across output load) <b>8.5VLP</b> 8.5 volts loop powered with 10-50mA (plus voltage across the output load)	None Available	<b>ECD</b> Thermoplastic, DIN-style housing mounts on 32 mm G-type (EN50035) and Top Hat (EN50022) rails

**When ordering, specify:** Unit / Input / Output / Power / Options [Housing]

**Model number example:** ECT / 4-20MA / 4-20MA / 5.5VLP [DIN]

## 4-Wire, Line (Mains) Powered Models

These ECT models are powered by standard 117Vac, 230Vac, and 24Vdc power supplies (Figure 6). They are designed for applications where line (mains) power is readily available, such as the back of a panel or in a control room.

**Figure 6.** 4-Wire, Line (Mains) Powered ECT

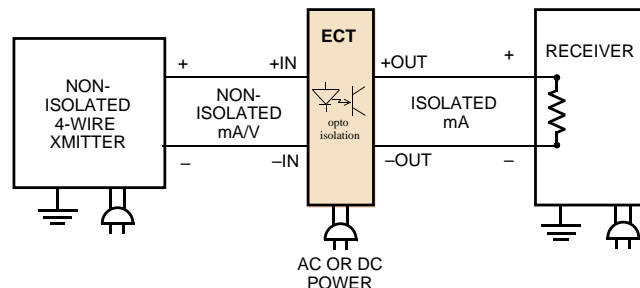

### Step Down Unsafe, High Level Signals

To protect plant personnel, the 4-wire ECT comes with an optional external input transformer (-EM option) to step down high level AC current inputs to a low-level signal. This permits safer servicing without opening the secondary of the customer's current transformer (Figure 7).

**Figure 7.** 4-Wire, ECT with Externally-Mounted Current Transformer (-EM Option)

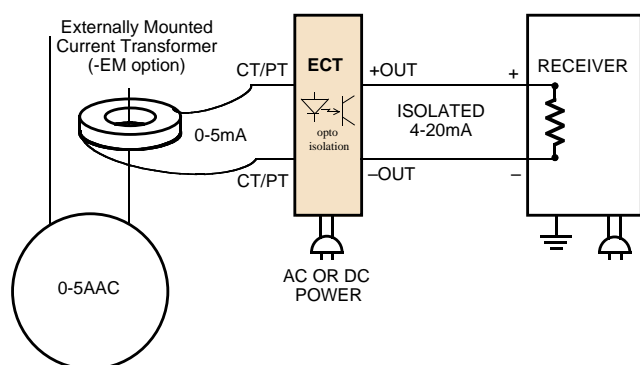

**Power a 2-Wire Transmitter**—With the -TX option, our 4-wire ECTs provide 24V power to a 2-wire, output-loop powered instrument. This eliminates the need for an additional power supply (Figure 8).

**Figure 8.** 4-Wire ECT with 2-Wire Transmitter Excitation (-TX Option)

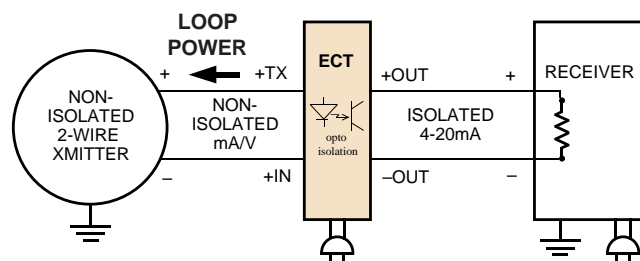

# ECT

## Signal Isolator/Converter

### 4-Wire, Line (Mains) Powered Models (continued)

#### “Sharing” or “Splitting” a Process Signal

The ECT with dual outputs will take one input and deliver two identical, completely isolated outputs (Figure 9). This is valuable for viewing one process variable at two locations, such as in custody transfer, where two parties require identical information for accountability or billing purposes.

Maintenance of one system does not disturb the information being collected at the second location. In addition, a failure at one receiver will not affect the second loop. This ECT can also be used to send the same signal to two separate monitoring or control devices.

Figure 9. 4-Wire ECT with Single Input and Dual Outputs

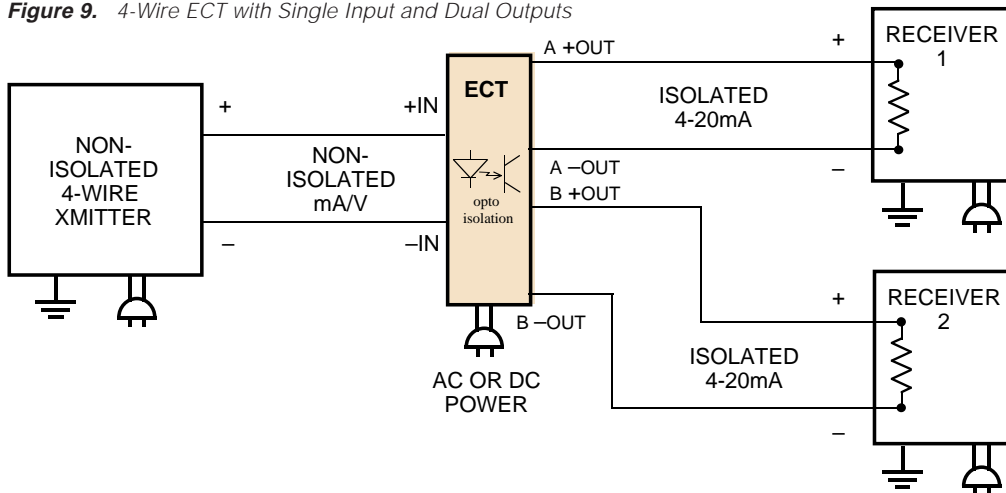

#### One Isolator Does the Work of Two

When ordered with dual input and output channels, the ECT will perform the functions of two isolators (Figure 10). Each of the ECT's two input-to-output channels is independent and completely isolated from the other.

Figure 10. 4-Wire ECT Dual Inputs and Dual Outputs

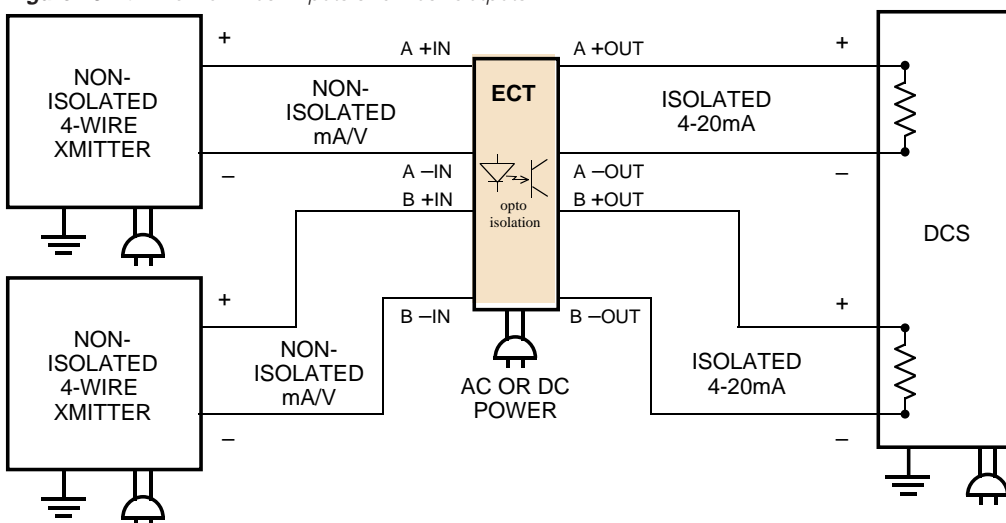

## 4-Wire, Line (Mains) Powered Models (continued)

### Specifications

#### 4-Wire, Line (Mains) Powered Models

<p><b>Performance Accuracy:</b> DC inputs: <math>\pm 0.1\%</math> of span; AC inputs: <math>\pm 0.5\%</math> of span  <b>Isolation:</b> 1500Vrms between input and output  <b>Common Mode Rejection:</b> Exceeds 95dB at 60Hz with a limit of 1,500Vrms  <b>Input Overrange:</b> 250% of full scale for dc current inputs; 200V peak max. for dc voltage inputs; 20AAC peak for 1 sec., 10AAC continuous for ac current inputs; 600V peak max. for ac voltage inputs</p>	<p><b>Performance (continued) Output Current Limiting:</b> 25mA typical; 30mA max.  <b>Ripple:</b> 10mV (measured across 250<math>\Omega</math> resistor)  <b>Response Time:</b> 100msec max. to 99% of output (400msec to 99% of output max. for 0-5A input)</p>	<p><b>Ambient Temperature Range:</b> -20°C to +70°C  -4°F to +158°F  <b>Effect:</b> <math>\pm 0.007\%</math> of span/°C typical; <math>\pm 0.015\%</math> of span/°C max.  <b>Humidity:</b> 0-95% non-condensing</p> <p><b>Adjustments Type:</b> Front panel pots  <b>Span:</b> <math>\pm 10\%</math>  <b>Zero:</b> <math>\pm 5\%</math> (non-interactive when span is set first)</p> <p><b>Weight</b> Single I/O: 221 g (7.8 oz)  Dual I/O: 280 g (9.9 oz)</p>
--	---	---

### Ordering Information

Unit	Input	Output	Power	Options	Housing
ECT 4-wire Line (Mains) powered Isolator/ Converter	SINGLE CHANNEL MODELS: <b>4-20MA</b> into 25 $\Omega$ <b>10-50MA</b> into 10 $\Omega$ <b>1-5V</b> into 1M $\Omega$ <b>0-10V</b> into 1M $\Omega$ <b>0-150AC</b> into 100K $\Omega$ <b>0-250AC</b> into 160K $\Omega$ <b>0-5AAC</b> into 0.002 $\Omega$	SINGLE OUTPUT CHANNEL: <b>4-20MA</b> into 1200 $\Omega$ <b>10-50MA</b> into 480 $\Omega$ <b>1-5V</b> into 5K $\Omega$ minimum <b>0-10V</b> into 5K $\Omega$ minimum	<b>24DC</b> , $\pm 10\%$ <b>117AC</b> , 50/60Hz, $\pm 15\%$ <b>230AC</b> , 50/60Hz, $\pm 15\%$ (3 watts max. for single channel models; 5 watts max. for dual channel models)	<b>-EM</b> Externally-mounted input transformer for current input (available with 0-5A (ac) input type only) <b>-TX</b> 2-wire transmitter excitation (24V @ 25mA) for powering a 2-wire transmitter connected on the loop	<b>ECT</b> Thermoplastic, DIN-style housing mounts on 32 mm G-type (EN50035) and Top Hat (EN50022) rails
	DUAL INPUT CHANNELS: <b>2X4-20MA</b> into 25 $\Omega$ <b>2X1-5V</b> into 1M $\Omega$ <b>2X0-10V</b> into 1M $\Omega$ (Other ac ranges also available)	DUAL OUTPUT CHANNELS: <b>2X4-20MA</b> into 1200 $\Omega$ <b>2X1-5V</b> into 5K $\Omega$ minimum <b>2X0-10V</b> into 5K $\Omega$ minimum			

**When ordering, specify:** Unit / Input / Output / Power / Options [Housing]

**Model number example:** ECT / 4-20MA / 4-20MA / 117AC / -TX [DIN]

#### Stop Ground Loop Noise!

Ground loops and other electrical interferences result in faulty readings in DCS, SCADA, and other signal measurement systems.

Our technical bulletin **Ground Loops: Causes & Cures** presents practical solutions to ending problems using signal isolators. Ask your Moore Industries Sales Engineer for a FREE copy.

#### Need Enhanced Features?

We also have a full line of isolators with special features:

**Superior Environmental Protection.** Aluminum DIN-style and explosion-proof enclosures are ideal for demanding applications.

**Unusual Inputs and Outputs.** We have isolators with a wide array of non-standard inputs and outputs.

**RFI/EMI Protection.** Some applications necessitate superior protection. We have the answer!

**Custom Signal Isolators.** We have engineers on-hand to modify our instruments to meet your unique needs.

# ECT

## Signal Isolator/Converter

**Figure 11.** Featuring a compact DIN-style housing, the ECT snaps securely on both G-type and Top Hat rails.

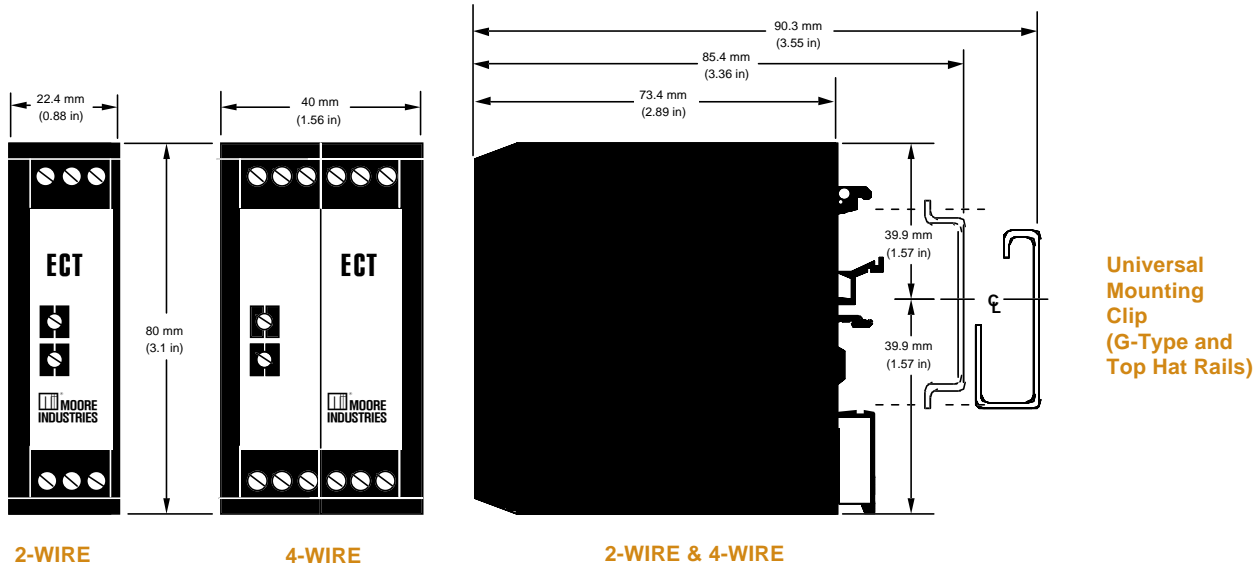

2-WIRE

4-WIRE

2-WIRE & 4-WIRE

**Table 1.** Terminal Designations

2-Wire (Loop-Powered) Models	Top Terminals (left to right)			Bottom Terminals (left to right)								
	1	2	3	4	5	6						
Output-Loop Powered	+IN	-IN		+PS	-PS							
Output-Loop Powered with 4-20MATX	+IN	-IN		+PS	-PS							
Output-Loop Powered & -EM Option	CT/PT	CT/PT		+PS	-PS							
Input-Loop Powered	+IN		-IN	+OUT		-OUT						

4-Wire (Line-Powered) Models	Top Terminals (left to right)						Bottom Terminals (left to right)					
	1	2	3	4	5	6	7	8	9	10	11	12
AC Power		+IN	-IN		AC	ACC	+OUT	-OUT				
AC Power & -EM Option	CT/PT	CT/PT			AC	ACC	+OUT	-OUT				
AC Power & -TX Option	+TX	+IN	-IN		AC	ACC	+OUT	-OUT				
AC Power & Single Input/Dual Outputs		+IN	-IN				A +OUT	A -OUT	B +OUT	B -OUT	AC	ACC
AC Power, Single Input/Dual Outputs & -TX Option	+TX	+IN	-IN				A +OUT	A -OUT	B +OUT	B -OUT	AC	ACC
AC Power & Dual Inputs/Dual Outputs		A +IN	A -IN		B +IN	B -IN	A +OUT	A -OUT	B +OUT	B -OUT	AC	ACC
AC Power, Dual Inputs/Dual Outputs & -TX Option	A +TX	A +IN	A -IN	B +TX	B +IN	B -IN	A +OUT	A -OUT	B +OUT	B -OUT	AC	ACC
DC Power		+IN	-IN		+DC	-DCC	+OUT	-OUT				
DC Power & -EM Option	CT/PT	CT/PT			+DC	-DCC	+OUT	-OUT				
DC Power & -TX Option	+TX	+IN	-IN		+DC	-DCC	+OUT	-OUT				
DC Power & Single Input/Dual Outputs		+IN	-IN				A +OUT	A -OUT	B +OUT	B -OUT	DC	DCC
DC Power, Single Input/Dual Outputs & -TX Option	+TX	+IN	-IN				A +OUT	A -OUT	B +OUT	B -OUT	DC	DCC
DC Power & Dual Inputs/Dual Outputs		A +IN	A -IN		B +IN	B -IN	A +OUT	A -OUT	B +OUT	B -OUT	DC	DCC
DC Power, Dual Inputs/Dual Outputs & -TX Option	A +TX	A +IN	A -IN	B +TX	B +IN	B -IN	A +OUT	A -OUT	B +OUT	B -OUT	DC	DCC



The Interface Solution Experts • [www.miinet.com](http://www.miinet.com)

**United States**  
Tel: (818) 894-7111  
FAX: (818) 891-2816

**Australia**  
Tel: (02) 9525-9177  
FAX: (02) 9525-7296

**Belgium**  
Tel: 03/448.10.18  
FAX: 03/440.17.97

**The Netherlands**  
Tel: (0)344-617971  
FAX: (0)344-615920

**United Kingdom**  
Tel: 01293 514488  
FAX: 01293 536852