

May 2003

Description

The universal CPA PC-Programmable Alarms provide on/off control, warn of unwanted process conditions, and provide emergency shutdown. Very economical, they accept a direct signal input from transmitters, temperature sensors, and a wide array of other monitoring and control devices:

- **Current and Voltage Signals**
- **23 RTD Types**
- **9 Thermocouple Types**
- **Resistance and Potentiometer Devices**
- **Direct Millivolt Sources**

Single or Dual Alarm Trip Outputs

The 4-wire (line/mains-powered) CPA provides one or two alarm relay outputs when a monitored process variable falls outside of user-set high and/or low limits. This is typically used to activate a warning light, annunciator, bell, or shutdown system.



The CPA PC-Programmable Alarm features a metal, RFI resistant housing that snaps onto standard DIN-style rails.

Features

- **Universal plant standard.** There's no need to stock dozens of different fixed range alarm trips.
- **20-bit input resolution.** Delivers industry-best digital accuracy for both sensor (RTD and thermocouple) and analog (current/voltage) inputs.
- **PC-programmable with Windows® software.** From a single screen, you can choose, and then view to confirm, all of your application specific operating parameters from a PC.
- **Long-term stability.** Provides up to 5 years between scheduled calibrations.
- **Combined alarm trip and transmitter.** The analog output (-AO) option reduces costs and installation time when both alarm and transmitter functions are needed at the same location.
- **Isolated and RFI/EMI protection.** Delivers superior protection against the effects of ground loops and plant noise, and radio frequency and electromagnetic interference.

Figure 1. Available CPA models deliver versatile and programmable input and output choices.

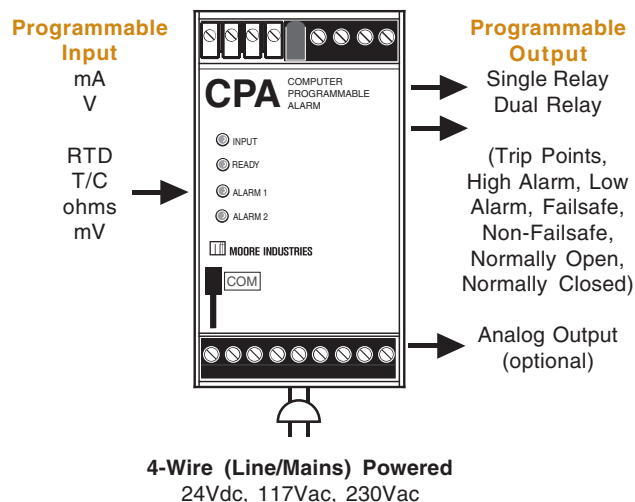

Certifications*

CE CE Conformant – EMC Directive 89/336/EEC
EN 61326; Low Voltage Directive 73/23/EEC EN 61010

* ATEX, CSA and FM certifications are in submittal.

CPA

PC-Programmable Current/Voltage
and RTD/Thermocouple Limit Alarm Trips

One Window. One Minute. One Setup.

All operating parameters configure quickly and easily using our Intelligent PC Configuration Software. Programmable functions include:

- Input type and measurement range (zero and full scale values)
- Input and output trimming
- High or low alarm(s) with trip points
- Failsafe or non-failsafe and normally open or normally closed alarm relays
- Alarm deadband (0-100%) and alarm time delay (0-120 seconds)
- T/C reference junction compensation (on/off)
- Standard and custom linearization curves
- Analog output range*
- On input failure, upscale or downscale drive, fail to last value, or fail to selected value*
- Analog signal output damping (0-120 seconds)*

*Models with Analog Output (-AO) option.

Powers a 2-Wire Transmitter

The CPA (HLPRG: current/voltage input model) comes standard with 2-wire transmitter excitation that provides 24Vdc to power the loop. This saves the cost of specifying and installing an additional instrument power supply.

Figure 3. The CPA provides transmitter excitation to power a 2-wire transmitter.

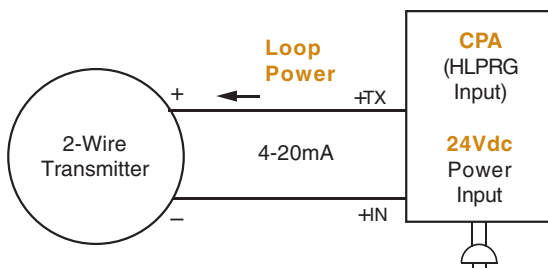

Figure 2. The CPA programs quickly from a single software window.



Programmable Process and Fault Alarms

Each individually-configurable CPA alarm trip relay programs via the PC software as a:

High or Low Process Alarm

Monitor a temperature, pressure, level, flow, position or status variable, and use to warn of unwanted process conditions, provide on/off control or provide emergency shutdown.

Input Fault Alarm

Setting one of the CPA's relays to trip on input or self-diagnostic failure (without affecting the other relay being used to monitor the process) is typically implemented to warn of a failure, such as a broken sensor, without tripping more critical process alarms or shutting down the process.

Self-Diagnostic Alarm

The CPA checks its own operation and configuration upon start up, and then continuously monitors its status during operation. One of the CPA's relays can be configured to trip if it senses that it is not operating properly.

Quick Ranging Calibration

Using the PC software (instead of potentiometers which can drift), precise zero and span settings can be made in seconds. Just select the zero and span values, and a push of a button on the PC keyboard locks the values into the CPA's memory.

Combination Alarm and Isolated Transmitter

When ordered with the Analog Output (-AO) option, the CPA provides a proportional and isolated analog retransmission of the input signal that can be sent to remote monitoring/control devices like a DCS, PLC, PC, indicator, or data recorder. All analog parameters can be selected using the CPA Intelligent PC Configuration Software.

Upon input failure, the analog output can be user-set for upscale or downscale drive, fail to last value, or fail to selected value.

Custom 128-Point Linearization Curves

The ability to plot a custom linearization curve is beneficial when non-linear input signals must be converted to linear output representations. Typical applications include monitoring a non-linear transducer, the level of odd-shaped tanks, and flow meter linearization.

Figure 4. Custom linearization points can be selected and saved in the CPA's memory to compensate for non-linear input signals.

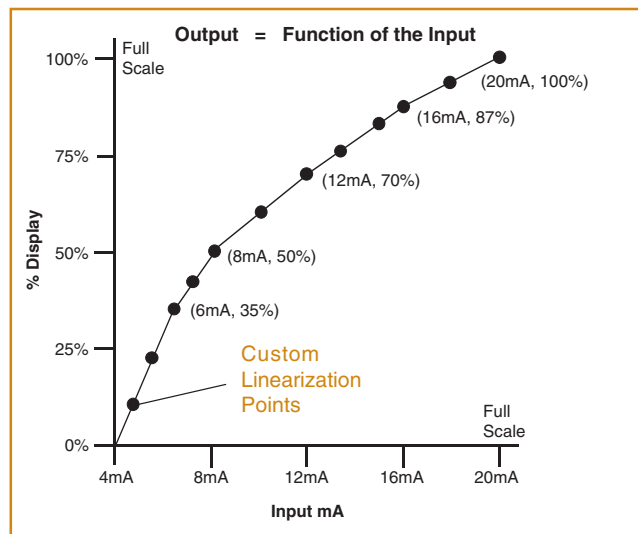

Superior Cold Junction Compensation

Uncompensated plastic terminals are very susceptible to ambient temperature changes that may result in readings that are "off" by several degrees. CPA models that accept temperature inputs (TPRG input) feature metal terminals and advanced electronic compensation techniques that provide a stable measurement in fluctuating ambient temperature conditions.

Figure 5. When ordered with the Analog Output (-AO) option, the CPA is a combination alarm trip and signal transmitter.

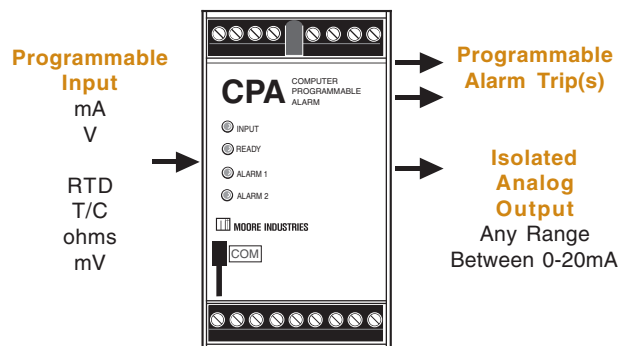

Trim to Specific Curve Segments

The CPA can be trimmed with two data points within the selected zero and span measurement range. This allows a complete process range to be monitored, while placing measurement emphasis on a critical segment of the range.

In the figure below, the ideal RTD curve is optimized between 20°C and 27°C to match the curve of the sensor used. This provides incredible precision over a limited portion of the span, while measuring the remainder of the span with outstanding accuracy.

Figure 6. The CPA can be set to measure the segment most critical to the process.

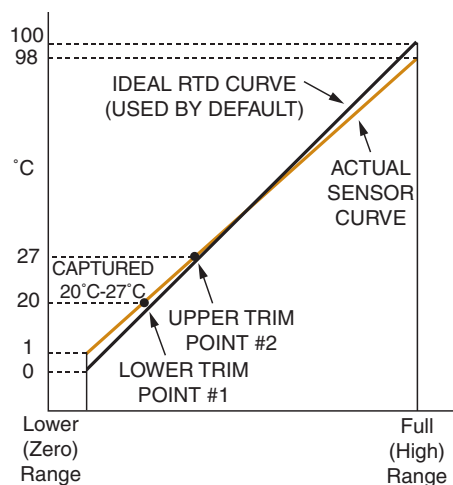

Total Sensor Diagnostics for RTD Inputs

If the RTD input breaks, the user can decide whether or not to trip one alarm to indicate trouble. A plain-English error message on the PC software indicates exactly which RTD wire has broken. Specific error messages eliminate the work of removing the sensor or checking all lead wires to diagnose a problem.

CPA

PC-Programmable Current/Voltage
and RTD/Thermocouple Limit Alarm Trips

Specifications (HLPRG: mA and V Input Model)

<p>Performance</p> <p>Alarm Trip Repeatability: Current, $\pm 0.01\%$ of max. span (± 2 microamps); Voltage, $\pm 0.01\%$ of max. span (± 1mV)</p> <p>Input Accuracy: Current, $\pm 0.01\%$ of max. span (± 2 microamps); Voltage, $\pm 0.01\%$ of max. span (± 1mV)</p> <p>Overall Accuracy: The overall accuracy of the unit is the combined input and output (if any) accuracies. It includes the combined effects of linearity, hysteresis, repeatability, and adjustment resolution. It does not include ambient temperature effect</p> <p>Minimum Span at Specified Accuracy: Current, 4mA; Voltage, 1V</p> <p>Stability: See Table 1</p> <p>Response Time: 300msec (Defined as time from step change on input to alarm state change when alarm is set to trip midpoint)</p> <p>Alarm Deadband: Programmable from 0-100%</p> <p>Alarm Trip Delay: 0-120 seconds</p> <p>Line Voltage Effect: $\pm 0.002\%$ of span per 1% change in line voltage (ac or dc)</p> <p>Isolation: Standard unit, 1000Vrms between case, input and output. 1500Vrms between power and input and between power and output.; Unit with -RF option, 500Vrms between case, input, output and power</p> <p>Power Consumption: 3W typical, 4W max.</p>	<p>Performance (continued)</p> <p>Power Supply Effect: $\pm 0.002\%$ of span per 1% of line change</p> <p>Input Impedance: 20ohms for current inputs; 1.1Mohm for voltage inputs</p> <p>Input Over-Range Protection: ± 100mA for current inputs; ± 30Vdc for voltage inputs</p> <p>WITH ANALOG OUTPUT:</p> <p>Output Accuracy: Current, $\pm 0.01\%$ of max span (± 2 microamps); Voltage, $\pm 0.01\%$ of max. span (± 1mV)</p> <p>Response Time: 256msec maximum (128msec typical) for the output to change from 10 to 90% of its scale for an input step change of 0 to 100%</p> <p>Ripple: 50mVp-p maximum on voltage output; 10mVp-p measured across a 250 ohm load resistor for current output (Frequencies up to 120Hz)</p> <p>Output Limiting: Input over range, -0.2V/0mA and 10.5V/21.4mA; Input failure, -0.5V/0mA and 11V/24mA</p> <p>Output Current Limiting: 25mA max.</p> <p>Load Effect (current outputs): 0.01% of span from 0 to maximum load resistance on current output</p> <p>Maximum Load Resistance: Current outputs, 1Kohm; Voltage outputs, 2Kohms</p>	<p>Indicators</p> <p>LED Type: INPUT LED: Dual color LED indicates input failure READY LED: Green LED indicates unit is operating properly ALARM 1 and ALARM 2 LED: Dual color LED per relay indicates alarm status</p> <p>Ambient Conditions</p> <p>Operating & Storage Range: -40°C to $+85^{\circ}\text{C}$ (-40°F to $+185^{\circ}\text{F}$)</p> <p>Relay Range: -25°C to $+70^{\circ}\text{C}$ (-13°F to $+158^{\circ}\text{F}$)</p> <p>Relative Humidity: 0-95%, non-condensing</p> <p>Ambient Temperature Effect: $\pm 0.015\%$ of maximum span/$^{\circ}\text{C}$</p> <p>RFI/EMI Immunity (Standard Unit): 10V/M@20-1000MHz, 1KHz when tested according to IEC1000-4-3-1995 with 0.5% of span or less error</p> <p>RFI Immunity (with -RF Option): 30V/M@20-1000MHz, 1KHz AM when tested according to IEC1000-4-3-1995 with 0.5% of span or less error</p> <p>Noise Rejection: Common mode: 100dB@50/60Hz; Normal Mode: Current Input, 100dB typical at 50mAp-p@50/60Hz; Voltage Input, 100dB typical at 1Vp-p@50/60Hz</p> <p>Weight 653 g (21 oz)</p>
---	---	---

Table 1. Long-Term Stability for HLPRG (mA and V) Input Model.

Stability (% of maximum span)	Input-to-Analog Output (Years)			Input-to-Relay Output (Years)		
	1	3	5	1	3	5
Current Inputs	0.081	0.14	0.18	0.047	0.081	0.105
Voltage Inputs	0.093	0.16	0.21	0.066	0.114	0.147

Specifications (TPRG: RTD, T/C, Ohm, mV and Pot Input Model)

<p>Performance</p> <p>Alarm Trip Repeatability: See Table 4 on Page 6</p> <p>Input Accuracy: See Table 4 on Page 6</p> <p>Overall Accuracy: The overall accuracy of the unit is the combined input and output (if any) accuracies. It includes the combined effects of linearity, hysteresis, repeatability, and adjustment resolution. It does not include ambient temperature effect</p> <p>Minimum Span at Specified Accuracy: See Table 4 on Page 6</p> <p>Cold Junction Compensation Accuracy (T/C Inputs Only): ±0.45°C</p> <p>Stability: See Table 2</p> <p>Response Time: 300msec (Defined as time from step change on input to alarm state change when alarm is set to trip midpoint)</p> <p>Alarm Deadband: Programmable from 0-100%</p> <p>Alarm Trip Delay: 0-120 seconds</p> <p>Line Voltage Effect: ±0.002% of span per 1% change in line voltage (ac or dc)</p> <p>Isolation: Standard unit, 1000Vrms between case, input and output. 1500Vrms between power and input and between power and output; Unit with -RF option, 500Vrms between case, input, output and power</p> <p>Power Consumption: 3W typical, 4W max.</p>	<p>Performance (continued)</p> <p>Power Supply Effect: ±0.002% of span per 1% of line change</p> <p>Input Impedance: T/C and mV inputs, 40Mohms, nominal</p> <p>Input Over-Range Protection: ±5Vdc</p> <p>Excitation Current (RTD and Ohm Inputs Only): 250microamps, ±10%</p> <p>Performance with Analog Output (-AO Option)</p> <p>WITH ANALOG OUTPUT:</p> <p>Output Accuracy: Current, ±0.01% of max. span (±2 microamps) Voltage, ±0.01% of max. span (±1mV)</p> <p>Response Time: 256msec maximum (128msec typical) for the output to change from 10 to 90% of its scale for an input step change of 0 to 100%</p> <p>Ripple: 50mVp-p maximum on voltage output; 10mVp-p measured across a 250 ohm load resistor for current output. (Frequencies up to 120Hz)</p> <p>Output Limiting: Input over range, -0.2V/0mA and 10.5V/21.4mA; Input failure, -0.5V/0mA and 11V/24mA</p> <p>Output Current Limiting: 25mA max.</p> <p>Load Effect (current outputs): 0.01% of span from 0 to maximum load resistance on current output</p> <p>Maximum Load Resistance: Current outputs, 1Kohms; Voltage outputs, 2Kohms</p>	<p>Indicators</p> <p>LED Type: INPUT LED: Dual color LED indicates input failure READY LED: Green LED indicates unit is operating properly ALARM 1 & ALARM 2 LED: Dual color LED per relay indicates alarm status</p> <p>Ambient Conditions</p> <p>Operating & Storage Range: -40°C to +85°C (-40°F to +185°F)</p> <p>Relay Range: -25°C to +70°C (-13°F to +158°F)</p> <p>Effect of Ambient Temperature on Cold Junction Compensation (T/C Inputs Only): ±0.005°C per °C change of ambient temperature</p> <p>Relative Humidity: 0-95%, non-condensing</p> <p>Ambient Temperature Effect: ±0.015% of maximum span/°C</p> <p>RFI/EMI Immunity (Standard Unit): 10V/M@20-1000MHz, 1KHz when tested according to IEC1000-4-3-1995 with 0.5% of span or less error</p> <p>RFI Immunity (with -RF Option): 30V/M@20-1000MHz, 1KHz AM when tested according to IEC1000-4-3-1995 with 0.5% of span or less error</p> <p>Noise Rejection: Common mode, 100dB@50/60Hz; Normal Mode, See Table 3</p> <p>Weight 653 g (21 oz)</p>
--	--	---

Table 2. Long-Term Stability for TPRG (RTD, T/C, mV, ohm, Pot) Input Model.

Stability (% of maximum span)	Input-to-Analog Output (Years)			Input-to-Relay Output (Years)		
	1	3	5	1	3	5
RTD, Ohm, & Pot Inputs	0.066	0.114	0.147	0.47	0.081	0.104
T/C & mV Inputs	0.047	0.082	0.106	0.008	0.014	0.019

Table 3. Normal Mode Rejection Ratio Table.

Sensor Type	Max. p-p Voltage Injection for 100dB at 50/60Hz
T/C: J, K, N, C, E	150mV
T/C: T, R, S, B	80mV
PT RTD: 100, 200, 300 ohms	250mV
PT RTD: 400, 500, 1000 ohms	1V
Ni: 120 ohms	500mV
Cu: 9.03 ohms	100mV
Resistance	mV
1-4kohms	250-1000
0.25-1kohms	62.5-250
0.125-0.25kohms	31.25-62.5

CPA

PC-Programmable Current/Voltage and RTD/Thermocouple Limit Alarm Trips

Table 4. Accuracy with RTD, Thermocouple, Ohms, and Millivolt Inputs (Models with TPRG Input).

Input	Type	α	Ohms	Conformance Range	Minimum Span	Input Accuracy/Repeatability	Maximum Range
RTD (2-, 3-, 4-Wire)	Platinum	0.003850	100	-200 to 850°C -328 to 1562°F	10°C (18°F)	±0.1°C (±0.18°F)	-240 to 960°C -400 to 1760°F
			200				
			300				
			400				
			500				
			1000				
	Platinum	0.003902	100	-100 to 650°C -148 to 1202°F	10°C (18°F)	±0.1°C (±0.18°F)	-150 to 720°C -238 to 1328°F
			200				
			400				
			500				
Platinum	0.003916	100	-200 to 510°C -328 to 950°F	10°C (18°F)	±0.1°C (±0.18°F)	-240 to 580°C -400 to 1076°F	
		Nickel	0.00672			120	-80 to 320°C -112 to 608°F
Copper	0.00427	9.035	-50 to 250°C -58 to 482°F	10ohms	±0.85°C (±1.53°F)	-65 to 280°C -85 to 536°F	
						Ohms	Direct Resistance
Ohms	Potentiometer	n/a	4000 max.	0-100%	10%	±0.1%	0-100%
	T/C	J	n/a	n/a	-180 to 760°C -292 to 1400°F	35°C 63°F	±0.25°C (±0.45°F)
T/C	K	n/a	n/a	-150 to 1370°C -238 to 2498°F	40°C 72°F	±0.3°C (±0.54°F)	-270 to 1390°C -454 to 2534°F
	E	n/a	n/a	-170 to 1000°C -274 to 1832°F	35°C 63°F	±0.2°C (±0.36°F)	-270 to 1013°C -454 to 1855.4°F
	T	n/a	n/a	-170 to 400°C -274 to 752°F	35°C 63°F	±0.25°C (±0.45°F)	-270 to 407°C -454 to 764.6°F
	R	n/a	n/a	0 to 1760°C 32 to 3200°F	50°C 90°F	±0.55°C (±0.99°F)	-50 to 1786°C -58 to 3246.8°F
	S	n/a	n/a	0 to 1760°C 32 to 3200°F	50°C 90°F	±0.55°C (±0.99°F)	-50 to 1786°C -58 to 3246.8°F
	B	n/a	n/a	400 to 1820°C 752 to 3308°F	75°C 135°F	±0.75°C (±1.35°F)	200 to 1836°C 392 to 3336.8°F
	N	n/a	n/a	-130 to 1300°C -202 to 2372°F	45°C 81°F	±0.4°C (±0.72°F)	-270 to 1316°C -454 to 2400.8°F
	C	n/a	n/a	0 to 2300°C 32 to 4172°F	100°C 180°F	±0.8°C (±1.44°F)	0 to 2338°C 32 to 4240.4°F
	mV	DC	n/a	n/a	-50 to 1000mV	4mV	15 microvolts

Ordering Information

Unit	Input	Output	Power	Options	Housing
CPA PC-Programmable Limit Alarm Trip	HLPRG Programs to accept: Current: Any range between 0-50mA including: 0-20mA 4-20mA 10-50mA Voltage: Any range between 0-10Vdc including: 0-5Vdc 1-5Vdc 0-10Vdc TPRG Programs to accept (see Table 3 on Page 6 for details): RTD: 2-, 3-, and 4-wire; platinum, copper, and nickel Thermocouple: J, K, E, T, R, S, N, C, B Ohms: 0-4000ohms (Potentiometer, 4000 ohms maximum) Millivolts: -50 to +1000mV	1PRG Single Relay (Relay is double-pole/double-throw (DPDT, 2 form C, rated 5A@250Vac, 50/60Hz, non-inductive) 2PRG Dual Relays (Relays are single-pole/double-throw (SPDT, 1 form C, rated 5A@250Vac, 50/60Hz, non-inductive) Each relay individually configures for: High or Low Trip Normally Open or Normally Closed Failsafe or Non-Failsafe	24DC ±10% 117AC ±10% 230AC ±10%	-AO Analog output (isolated and linearized) scaleable for any range between 0-20mA or 0-10V (see "Specifica- tions" for additional information) NOTE: Output can be user-set for internal or external power (source or sink) -RF Enhanced RFI/EMI protection (see "Specifications" for details) -HS Hermetically sealed relays, rated 0.5A@117Vac and 2A@28Vdc	DIN Universal DIN-style housing mounts on 32mm (EN50035) G-type and 35mm (EN50022) Top Hat DIN-rails

When ordering, specify: Unit / Input / Output / Power / Options [Housing]

Model number example: CPA / TPRG / 2PRG / 117AC / - AO -RF [DIN]

Accessories

Each CPA order comes with one copy of our Intelligent PC Configuration Software (Windows® '95, '98, 2000, NT and XP compatible) and a configuration cable. Use the chart below to order additional parts.

Part Number 225-75120-01	CPA/CPT Intelligent PC Configuration Software (One copy provided free with each order)
Part Number 803-053-26	CPA/CPT Configuration Cable for use in connecting the CPA/CPT to the PC (one cable provided free with each order)

CPA

PC-Programmable Current/Voltage and RTD/Thermocouple Limit Alarm Trips

Figure 7. Installation Dimensions.

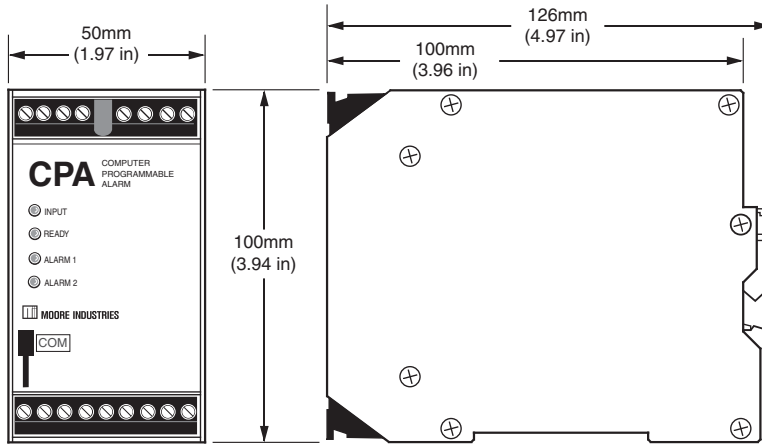

NOTE: While all CPA models (model with HLPARG input shown) are dimensionally identical, the CPA that accepts temperature inputs (TPRG input) features metal terminal blocks for enhanced cold junction compensation.

Table 5. Terminal Designations.

Input Type	Top Terminals (Left to Right)								
	T1	T2	T3	T4	T5	T6	T7	T8	T9
Current Input (HLPARG)	Tx	+I	COM	Not Used	Not Present	+IO Source	-IO Source +IO Sink	+VO	-VO -IO Sink
Voltage Input (HLPARG)	Tx	Not Used	COM	+V	Not Present	+IO Source	-IO Source +IO Sink	+VO	-VO -IO Sink
RTD, Ohm & Pot Input (TPRG)	See Figure 8				Not Present	+IO Source	-IO Source +IO Sink	+VO	-VO -IO Sink
T/C & mV Input			+	-	Not Present	+IO Source	-IO Source +IO Sink	+VO	-VO -IO Sink

Output Type/Power	Bottom Terminals (Left to Right)								
	B1	B2	B3	B4	B5	B6	B7	B8	B9
Single Alarm (DPDT Relay)	NO1	CM1	NC1	NO2	CM2	NC2	AC/DC	ACC/DCC	GND
Dual Alarms (SPDT Relays)	Relay 1 NO1	Relay 1 CM1	Relay 1 NC1	Relay 2 NO2	Relay 2 CM2	Relay 2 NC2	AC/DC	ACC/DCC	GND

NOTES:

- Terminal blocks can accommodate 14-22 AWG solid wiring.
- \pm IO/ \pm VO labeling is present only when the unit is equipped with the Analog Output (-AO) option.

KEY:

- | | | |
|---------------------------------|----------------------|---------------------------------|
| AC/DC = Power Input | IO = Current Output | Source = Current Source |
| ACC/DCC = Power Input | NO = Normally Open | SPDT = Single-Pole/Double-Throw |
| CM = Relay Common | NC = Normally Closed | VO = Voltage Output |
| COM = Analog Common | Sink = Current Sink | |
| DPDT = Double-Pole/Double-Throw | | |
| GND = Ground | | |

Figure 8. Temperature Sensor Hook-Up Guide (Models with TPRG Input).

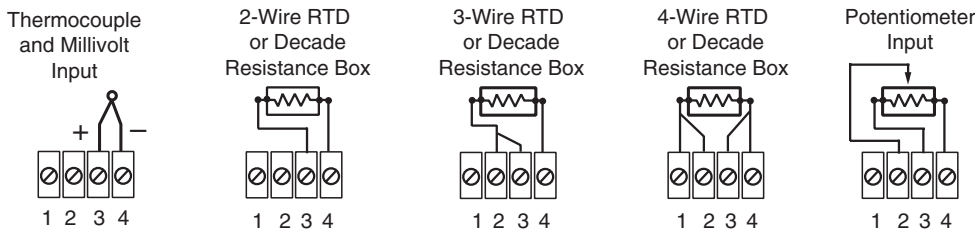

The Interface Solution Experts • www.miinet.com
 United States • info@miinet.com
 Tel: (818) 894-7111 • FAX: (818) 891-2816
 Australia • sales@mooreind.com.au
 Tel: (02) 8536-7200 • FAX: (02) 9525-7296

Belgium • info@mooreind.be
 Tel: 03/448.10.18 • FAX: 03/440.17.97
 The Netherlands • sales@mooreind.nl
 Tel: (0)344-617971 • FAX: (0)344-615920

China • sales@mooreind.sh.cn
 Tel: 86-21-62481120 • FAX: 86-21-62490635
 United Kingdom • sales@mooreind.com
 Tel: 01293 514488 • FAX: 01293 536852