



Modbus/RS-485



932/934MB Multi-Channel Temperature Control Modules

RTD or Resistance Input

Limit Alarms or Discrete Outputs

Models

932MB: 2 input channels, 2 relay outputs

934MB: 4 input channels, 4 relay outputs

Input

RTD (100 ohm Pt, 120 ohm Ni, 10 ohm Cu), Resistance (0 to 500 ohms)

Output

Solid-state relays, Form A, SPST-NO

Network Communication

Modbus-RTU high-speed RS-485

Power Requirement

10 to 36V DC,
24V AC

Approvals

CE marked. UL, cUL listed
Class I; Division 2; Groups A, B, C, D.

RTD/Resistance Input Module

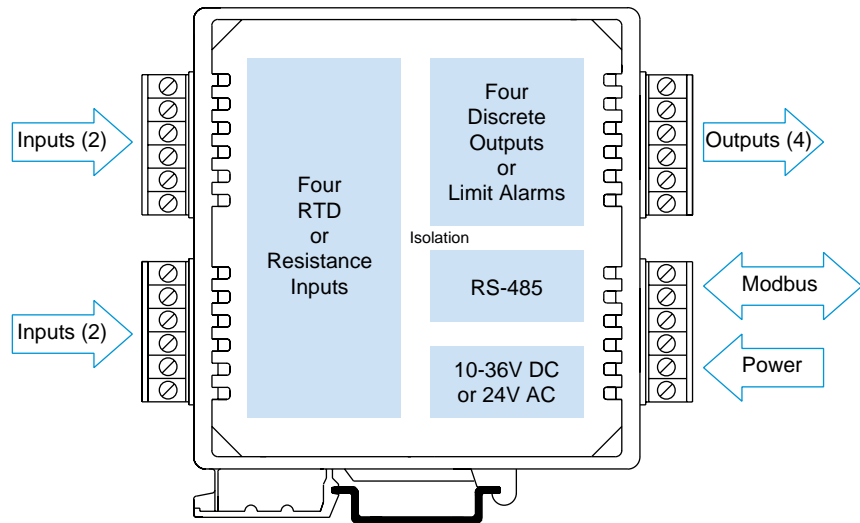

Description

This signal conditioner is a dual or quad-channel analog input module with one discrete/relay output per input channel and a Modbus interface. It filters and linearizes RTD or resistance inputs while providing isolation between input, output, power, and network circuits. Lead wire compensation and upscale/downscale sensor break detection are standard. Low voltage AC and DC power sources are supported with nonpolarized, diode-coupled terminals.

The programmable inputs accommodate four RTD types plus wide-range resistance signals. Flexible discrete outputs operate as alarms or on/off controllers. As limit alarms, each discrete output can be configured with high and/or low setpoints exclusively tied to an analog input channel. Alarm trips function without host communication enabling low-cost stand-alone alarms as well as local backup for the primary control system. Otherwise, on/off control is based on commands issued by the host system.

Combining flexible transmitter functions, mixed signal I/O, alarm support, and a network interface in a single package, makes this instrument extremely powerful. Multi-channel design adds cost-efficiency and allows high-density mounting. Plus, safe, rugged construction makes these modules reliable for use in both control room and distributed field I/O applications. Custom module configurations are also possible (consult factory for details).

Special Features

- Standard Modbus RTU protocol with high-speed RS-485 communication (up to 115K bps)
- 16-bit sigma-delta A/D yields 0.1°C resolution and 0.25°C accuracy (Pt, Ni RTDs)
- RTD linearization and sensor break detection ensure reliable measurements
- Discrete relay outputs enable local temperature limit alarms or host-controlled on/off switching
- Heavy-duty 1A solid-state relays provide dependable on/off control of industrial devices
- Self-calibration lowers maintenance costs by reducing periodic manual calibration checks
- Watchdog timers provide a configurable failsafe output state for use when host I/O communication is lost
- Four-way isolation eliminates potential ground loops between power, input, output and network circuitry
- Self-diagnostics monitor microcontroller activity to detect operational failures (lock-up) and execute a reset to restore communication



Performance

RTD/Resistance Input

Input Ranges

Input type user-configured. Type selected applies to all channels. RTD linearization, lead wire compensation, and open circuit or lead break detection are included.

Input Type	Alpha	Input Range	Accuracy
Pt 100 ohm	1.3850	-200 to 850°C	±0.25°C
Pt 100 ohm	1.3911	-200 to 850°C	±0.25°C
Ni 120 ohm	1.6720	-80 to 320°C	±0.25°C
Cu 10 ohm	1.4272	-200 to 260°C	±1.00°C
Resistance	linear	0 to 500 ohms	±0.05 ohm

Resolution

Input Type	Alpha	Resolution
Pt 100 ohm	1.3850	0.1°C
Pt 100 ohm	1.3911	0.1°C
Ni 120 ohm	1.6720	0.1°C
Cu 10 ohm	1.4272	0.2°C
Resistance	linear	7.8125 milliohms

Ambient Temperature Effect

Better than ±0.005% of input span per °C, or ±1.0uV/°C, whichever is greater.

Noise Rejection

Normal mode: 40dB @ 60Hz, typical.
Common mode: 130dB @ 60Hz, typical.

Input Filter Bandwidth

-3dB at 3Hz, typical.

Input Conversion Rate

300ms per channel typical.

RTD Break Detection

Sensor failure can be configured for either upscale or downscale. Selection applies to all channels.

Excitation Current

1mA DC typical, all types.

Lead-Wire Compensation

Inherent for 3-wire RTD. The maximum lead resistance is 25 ohms per lead (Pt), 20 ohms per lead (Ni), 10 ohms per lead (Cu). All lead wires must be of equal size and length.

Discrete Output

Output Type

Solid-State Relay (SSR), one Form A (SPST-NO) switch per input channel. Outputs share a common return connection at the RTN terminals for low side switching

Output Voltage Range

0 to 48V DC, 1A DC.

Output ON Resistance

0.4 ohms maximum.

Output Response Time

4.1ms typical, from receipt of command to gate transition of the output MOSFET.

Operation

Digital outputs are set to their OFF state following a software or power-on reset. Outputs can be set to user-defined states following a watchdog timeout.

Communication

Supported Modbus Commands

The command/response protocol for communicating with this module adheres to the Modbus/RTU standard for the following Modbus Functions.

Read Holding Registers	Read Coil
Read Input Registers	Reset Slave
Preset Single Register	Report Slave ID
Force Multiple Coils	Force Single Coil
Preset Multiple Register	

LED Indicators

LEDs indicate power, status, and discrete level/alarm.

Power and Isolation

Power Requirements

10 to 36V DC (56mA max. at 24V DC).
22 to 26V AC (94mA rms max. at 24V AC).

Isolation

1500V AC for 60 seconds or 250V AC continuous. 4-way isolation between input, network, power and discrete I/O circuits. Inputs are isolated channel-to-channel for common mode voltage to ±5V DC.

Ordering Information

932MB-0900

Two channel RTD/Resistance input module

934MB-0900

Four channel RTD/Resistance input module

Accessories

900C-SIP

Configuration Software Interface Package (includes software CD-ROM for Windows, RS-232/485 converter, and RS-485/three-wire cable)

5034-225

USB-to-RS232 adapter. See page 59 for more info.

TBK-B02

Optional terminal block kit, barrier strip style, 4 pcs.

TBK-S02

Optional terminal block kit, spring clamp style, 4 pcs.

PS5R-D24

Power supply (24V DC, 2.1A).
See Power Supplies on page 213.

For more information on software, network hardware, and mounting accessories, please see Pages 57-59.



Optional terminal blocks: barrier strip (left) and spring clamp (right). Cage clamp terminal is standard.

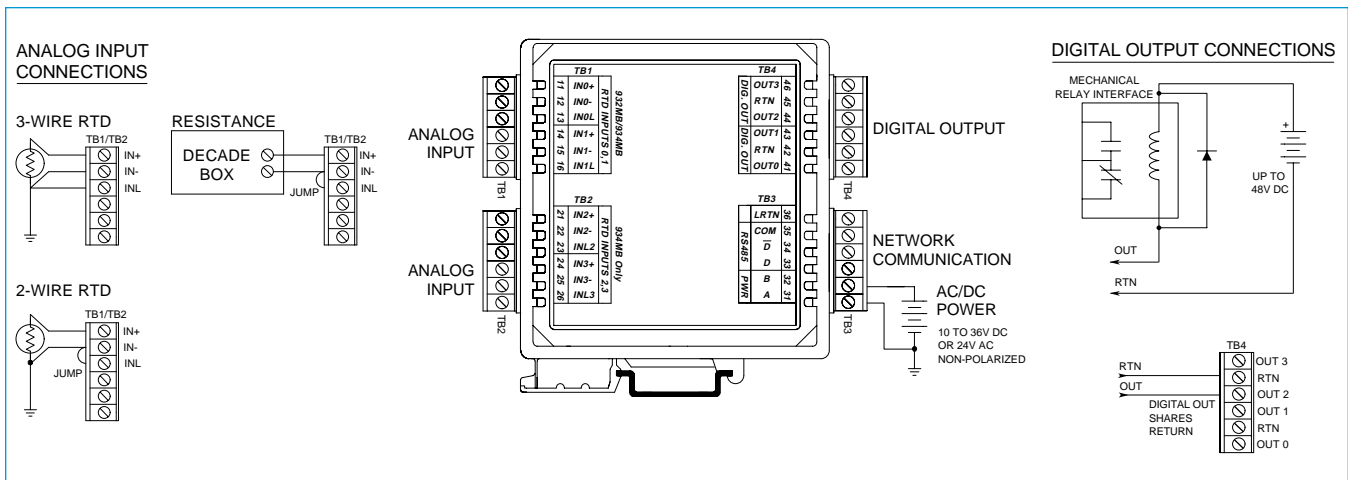



■ Accessories

■ Configuration Tools

Acromag provides a full set of tools to help you get your modules set up and ready to install.

Software Interface Package

See Page 57 for more information.

Includes the following:

- Configuration Software Utility
- Instruction manuals
- Serial port converter
- Interface cable

■ Network Devices

Everything you need to drive your network is available from Acromag: isolators, converters, signal boosters, and power sources.

Universal 50W Power Supply (Page 57)

Isolated RS-232/485 Converter (Page 58)

Isolated RS-485 Network Repeater (Page 58)

■ Mounting Hardware

Installation is a snap with Acromag accessories.

DIN RAIL Bars (Page 57)

19" Rack-Mount Kit (Page 57)

■ General Module Specifications

■ Communication Interface

Network Communication

Modbus-RTU protocol, RS485 (3-Wire). Standard Protocol implementation as defined under "Modicon Modbus Reference Guide" PI-MBUS-300 Rev. J. Reference: <http://public.modicon.com>. Search on: PI-MBUS-300 for technical publication.

Baud Rate

2400, 4800, 9600, 14.4k, 19.2k, 28.8k, 38.4k, 57.6k, 76.8k, or 115.2k baud. Default 9600 baud.

Module Addressing

0 to 247, selectable. Default address 247.

Network Distance

4000 feet without network repeater.

Nodes

Supports up to 32 modules without the use of a network repeater.

Parity

Odd, even, or none. Default setting none.

Stop Bits

One with parity, one or two with no parity. Default setting is two stop bits with no parity.

Watchdog Timer (Hardware)

A hardware watchdog timer is built into each module to perform a reset if the microcontroller fails to return from an operation in a timely manner or "locks up".

Watchdog Timer (Network Communication)

All modules have a communication watchdog timer function. The watchdog timer is configurable for timeout periods of up to 18 hours. This timer function monitors I/O communications with the host controller. In the event of lost communications, output ports optionally reset to a user-defined state or level. The watchdog timer restarts with a read/write to an I/O channel.

■ Environmental

Ambient Temperature

Operation: -25°C to +70°C (-13°F to +158°F). Storage: -40°C to +85°C (-40°F to +185°F).

Relative Humidity

5 to 95% non-condensing.

Radiated Field Interference Immunity (RFI)

Complies with EN61000-4-3 Level 2 and EN50082-1 (3V/M, 80 to 1000MHz AM and 900MHz keyed).

Electrical Fast Transient Immunity (EFT)

EN61000-4-4 Level 1 and EN50082-1 (0.5KV power, signal lines).

Electrostatic Discharge (ESD) Immunity

EN61000-4-2 Level 3 and EN50082-1 (8KV/4KV air/direct discharge).

Surge Immunity

EN61000-4-5 (0.5KV) and EN50082-1.

Radiated Emissions

Meets EN50081-1 for Class B equipment.

Approvals

CE marked. UL listed for US and Canada. Class I; Division 2; Groups A, B, C, D.

■ Enclosure/Physical

Enclosure

Self-extinguishing NYLON type 6.6 polyamide thermoplastic UL94 V-2, color beige; general purpose NEMA Type 1 enclosure.

Connectors (Removable Terminal Blocks)

Wire Range: AWG #12-24, stranded or solid copper.

Dimensions

1.05W x 4.68H x 4.35D inches
26.7W x 118.9H x 110.5D mm.

DIN Rail Mounting

DIN rail mount, Type EN50022; "T" rail (35mm).

Shipping Weight

1 pound (0.45 Kg) packed.

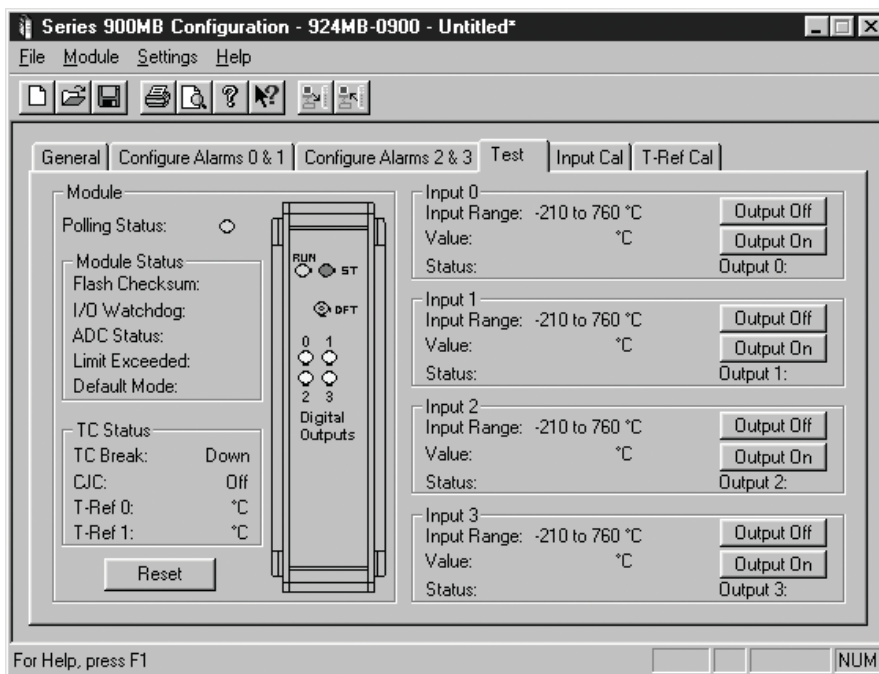

A test page simplifies diagnostics with a live visual display of the module's input and output values.



Configuration Kit

Software Interface Package
Model No. 900C-SIP

RS-485 Cable (DB-9)

RS-232 to RS-485 Converter (non-isolated)

Configuration Software for Windows

Software Interface Package

This package includes Windows® Configuration Software, an RS-232-to-485 Serial Port Converter, and an RS-485 Signal Cable. These components provide everything you need to set up a Series 900 I/O module from your desktop PC before installing it on the network.

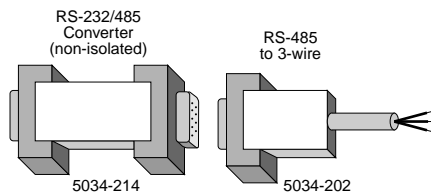

Ordering Information

- 900C-SIP
Software Interface Package.
Includes Configuration Software (5034-186), Non-isolated RS-232 to RS-485 Serial Port Converter (5034-214), and RS-485 Cable (5034-202).
Items can also be ordered separately below.
- 5034-186
Configuration Software for Windows (95/98/2000/ME/NT4/XP) on CD-ROM.
- 5034-214
Non-isolated RS-232 to RS-485 Serial Port Converter, DB-9F to DB-9F.
- 5034-202
RS-485 to 3-wire Cable Converter, DB-9M to 3 x 12AWG RS-485 Cable, 8 ft.

Network Power

CE UL US LISTED TUV

Universal 50W Power Supply

The PS5R-D24 is the ideal power source to drive your network.

Input Power Requirement
Universal power
85 to 264V AC,
105 to 370V DC

Output
24V DC, 2.1A (50W)

Ordering Information

- PS5R-D24
Universal Power Supply

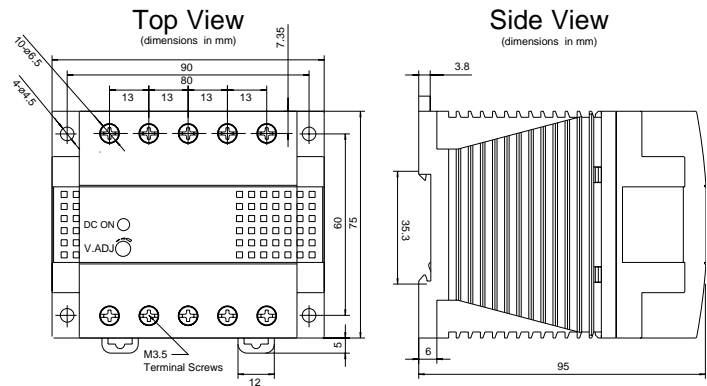

Mounting Hardware

DIN-Rail Mounting

For your convenience, Acromag offers several mounting accessories to simplify your system installation. Our 19" rack-mount kit provides a clean solution for mounting your I/O modules and a power supply. Or you can buy precut DIN rail strips for mounting on any flat surface.

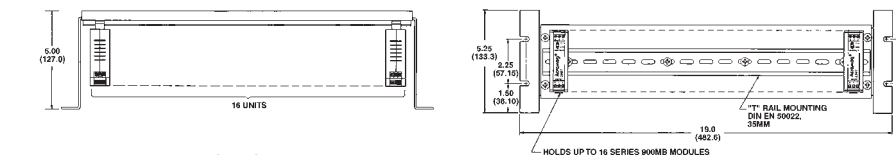

Ordering Information

- 20RM-16-DIN
19" rack-mount kit with DIN rail.
- DIN RAIL 3.0
DIN RAIL 16.7
DIN rail strip, Type T, 3 inches (75mm) or 16.7 inches (425mm)



RS-232 to RS-485



4SCC-TTM Isolated Signal Converter

This unit provides an isolated interface between the host PC's RS-232 port and RS-485 Modbus network devices. Signal conversion is bidirectional with operation that is transparent to all devices. The RS-485 network supports up to 32 devices (including the 4SCC-TTM Converter) across 4000 foot distances. Installation of additional network devices or extending the distance requires the 4SCR-TTM Network Repeater.

Specifications

Baud Rates
Switch-selectable from 300 to 38.4K baud.

Duplex
Half duplex only.

Network Termination Resistors
Two terminal blocks and 120 ohm resistors provided to terminate both ends of the RS-485 network.

Wiring Connectors
Terminal blocks with screw clamps for 14-26AWG.

Operating Temperature Range
-25 to 60°C (-13 to 140°F).

Isolation
Withstands 1500V AC surge for 60 seconds (250V AC or 354V DC continuous).

Ordering Information

4SCC-TTM-1
Signal Converter, 115V AC (power cord included)

4SCC-TTM-2
Signal Converter, 230V AC (power cord included)

5020-924
Signal Cable, 8ft. long, DB-9 to three wires. Connects PC's RS-232 port to 4SCC-TTM-x.

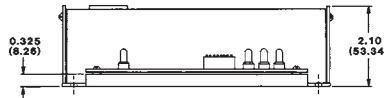
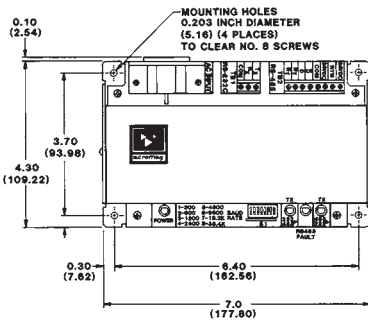

Dimensions in inches (mm).
Shipping Weight
3.0 lbs. (1.4 kg) packed.

BusWorks® Modbus I/O

RS-485 to RS-485



4SCR-TTM Isolated Network Repeater

This unit isolates and boosts RS-485 signals to extend communication distances or increase the number of devices on the network. Each Repeater permits the addition of a network branch with up to 32 devices (including the 4SCR-TTM) and will transmit RS-485 signals another 4000 feet. Operation is transparent to all devices and no handshaking is required. Two terminal blocks are provided for 120 ohm resistors to terminate both ends of the network branch.

Specifications

Baud Rates
Switch-selectable from 300 to 38.4K baud.

Duplex
Half duplex only.

Network Termination Resistors
Two terminal blocks and 120 ohm resistors provided to terminate both ends of the RS-485 network.

RS-485 Wiring Connectors
Terminal blocks with screw clamps for 14-26AWG.

Power Wiring Connections
Terminal block with screw clamps for 12-18AWG.

Operating Temperature Range
-25 to 60°C (-13 to 140°F).

Isolation
Withstands 1500V AC surge for 60 seconds (250V AC or 354V DC continuous).

Ordering Information

4SCR-TTM-1
Signal Converter, 115V AC power

4SCR-TTM-2
Signal Converter, 230V AC power

40LC-GBW-1
115V AC power cord

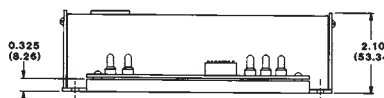
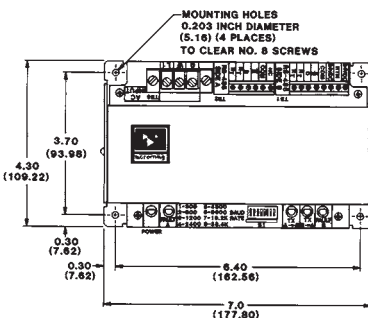

Dimensions in inches (mm).
Shipping Weight
3.0 lbs. (1.4 kg) packed.



System Connection

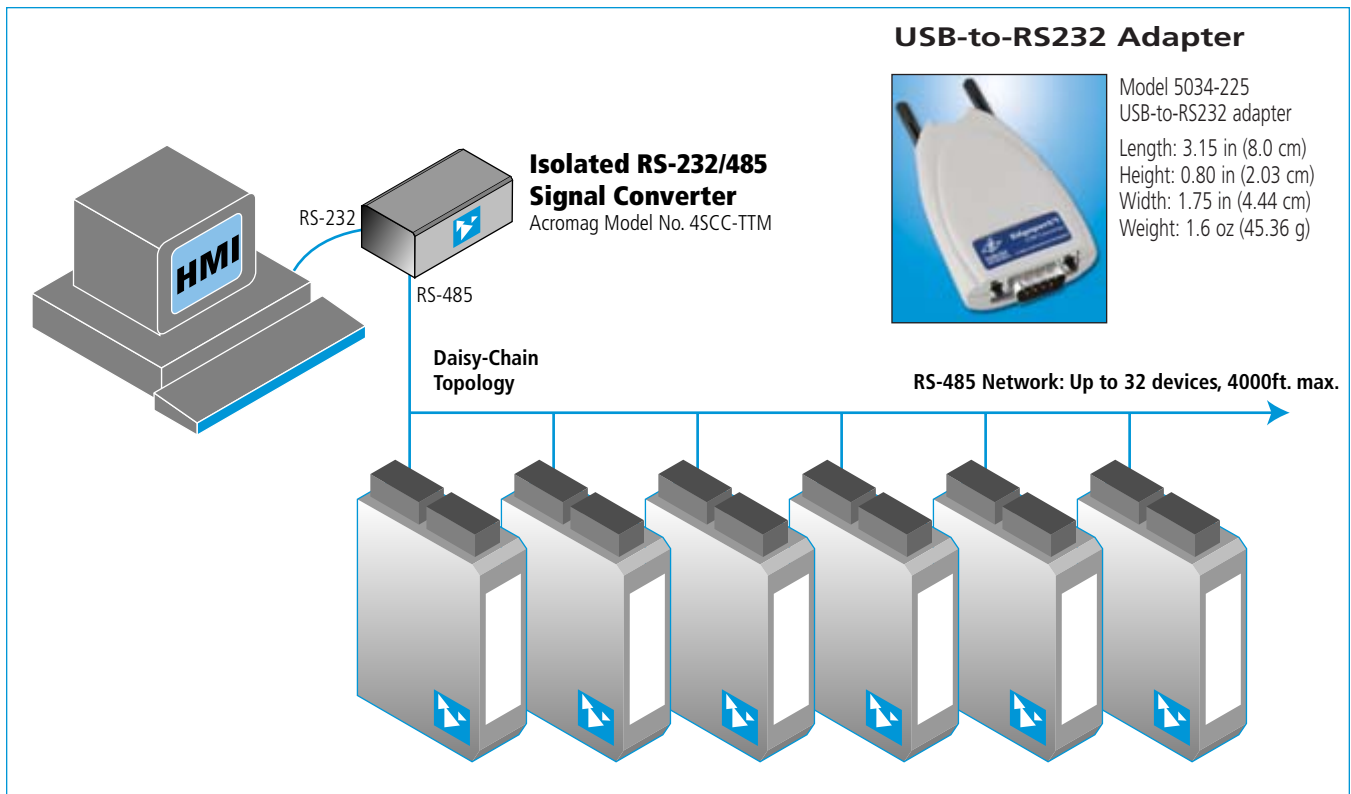

BusWorks® Modbus I/O

Extending the Network

